

# **STATISTICS OF AC UNDERGROUND CABLES IN POWER NETWORKS**

**Working Group  
B1.07**

**December 2007**



## WG B1.07

# Statistics of AC underground cables in Power networks

### Working Group B1.07 Members

Steve Swingler - UK (Convenor)  
John Daly - Ireland (Secretary)  
Ken Barber - Australia  
Rudolf Woschitz - Austria  
Alain Gille - Belgium  
Ray Awad - Canada  
Josip Antic - Croatia  
Christian Jensen - Denmark  
Anne Chauvancy\* - France  
Matthias Kirchner - Germany  
Ernesto Zaccone\* - Italy  
Masao Matsumura - Japan  
Gert Aanhaanen - Netherlands  
Christer Akerwall\* - Sweden  
Walter Zenger - USA

\*The original members of the working group were Monique Le Stum, Marcello Del Brenna and Johan Karlstrand

### **Copyright © 2007**

*“Ownership of a CIGRE publication, whether in paper form or on electronic support only infers right of use for personal purposes. Are prohibited, except if explicitly agreed by CIGRE, total or partial reproduction of the publication for use other than personal and transfer to a third party; hence circulation on any intranet or other company network is forbidden”.*

### **Disclaimer notice**

“CIGRE gives no warranty or assurance about the contents of this publication, nor does it accept any responsibility, as to the accuracy or exhaustiveness of the information. All implied warranties and conditions are excluded to the maximum extent permitted by law”.

**ISBN 978-2-85873-026-1**

## TABLE OF CONTENTS

<b>EXECUTIVE SUMMARY</b>	<b>i</b>
<b>1 INTRODUCTION</b>	<b>1</b>
<b>2 STATISTICS OF INSTALLED LENGTHS</b>	<b>3</b>
<b>3 TECHNICAL CONSIDERATIONS</b>	<b>11</b>
3.1 Electrical Insulation	11
3.2 Heat transfer	14
3.3 Construction and Installation	18
3.4 Electrical Design	27
3.5 Operation	29
3.6 Reducing the cost of undergrounding	32
<b>4 COST FACTORS</b>	<b>34</b>
4.1 Cost Ratios	35
4.2 Components of cost for cable systems	36
4.3 Comparing underground and overhead options	36
<b>5 CONCLUSIONS</b>	<b>38</b>
<b>6 REFERENCES</b>	<b>40</b>

## APPENDICES

<b>A STATISTICS OF INSTALLED LENGTHS</b>	
A.1 Collection of Data	
A.2 Data received	
A.3 Comparison with the 1996 study	

## **B THERMAL DESIGN**

- B.1 Load and Ratings
- B.2 Nominal Ratings
- B.3 Short-term Ratings
- B.4 Real-time Ratings
- B.5 Prediction of Ratings
- B.6 Ratings of hybrid overhead/underground networks

## **C ELECTRICAL DESIGN**

- C.1 Protection
- C.2 Special Bonding
- C.3 Parallel lines
- C.4 Reactive Compensation

## **D CONSTRUCTION AND INSTALLATION**

- D.1 Laying Techniques
- D.2 Installation Methods
- D.3 Environmental Considerations

## **E OPERATION**

- E.1 Uprating
- E.2 Monitoring

## **F COST ESTIMATION**

- F.1 Components of cost for underground cable systems
- F.2 Components of cost for overhead line systems

## **G SIGNIFICANT CABLE PROJECTS**

## Executive Summary

### Preamble

In the mid 1990s CIGRE Study Committees 21 (HV insulated Cables) and 22 (Overhead lines) set up a Joint Working Group to compare high voltage overhead transmission lines and underground cables. The report (Technical Brochure 110) examined the extent to which the two systems were used worldwide and the cost implications. In 2003 CIGRE Study Committee B1 decided that a new Working Group (WG B1.07) should be set up to update the work done in the 1990s.

The terms of reference of WG B1.07 were:

- To collect statistics for the lengths of underground and overhead circuits at a range of transmission voltages. Only existing lines and projects planned for implementation by 2006 should be included,
- To describe significant underground cable projects realised in the period 1996-2006 giving the reasons why undergrounding was selected,
- To describe the factors which must be considered when evaluating the cost of overhead or underground connections,
- To describe the other factors which must be taken into account in order to make a balanced choice between overhead and underground technology.

Submarine cables are excluded from the scope of work. DC cables are also excluded since these are predominantly submarine. The voltage range is restricted to system voltages from 50 kV, which limits the scope to transmission systems and the high end of the distribution voltage range.

### Introduction

Chapter 1 of this Technical Brochure (TB) sets out the background to the present work and details the scope and Terms of Reference of WG B1.07.

Some significant changes have taken place since the 1996 report was published. A number of weather-related incidents on overhead lines have led some utilities to revise their meteorological design parameters leading to increased costs. Technical changes and strong competition in the cable sector have reduced prices. Increased urbanisation and public concerns have increased the difficulty and time taken to obtain consents for overhead lines. There have been broad changes in the structure of electricity supply and in the nature of demand, for example the load peak in some regions is shifting from winter to summer. In view of these changes WG B1.07 has updated the statistics on circuit lengths and produced guidance on the technical and cost factors influencing the choice between underground cable and overhead line.

The Brochure also looks at some of the main technical factors which influence the cost and complexity of underground cable systems.

Some significant cable projects undertaken in the last 10 years are described. The definition of a significant cable project is difficult. The WG decided that it is a cable project at 50 kV or above, which is likely to be of broad international interest and containing some element of innovation. The project can be significant in engineering, commercial, environmental or social terms.

The brief project descriptions give basic details of the cable type, installation methods and the reasons for their choice. Details of the power carrying capability (rating) are generally included together with information on why underground cable was selected rather than overhead line.

## **Statistics of installed lengths**

Data on the lengths of ac underground cable and overhead line currently installed were collected by a questionnaire sent to Study Committee members. The statistics were divided into five voltage ranges chosen in order to group together similar design and operational principles. The voltage ranges are: 50-109 kV, 110-219 kV, 220-314 kV, 315-500 kV and 501-764 kV.

In some cases, data capture proved difficult, particularly for countries with a multitude of small independent utilities (for example the USA and Germany). In addition, the national systems for maintaining such data have been discontinued in some countries, as utilities have been released from state control and experienced reorganisation, merger and acquisition.

Chapter 2 reports the circuit lengths of ac overhead line and underground cable currently installed not the increase in length since the 1996 report. The total length of underground cable circuit expressed as a percentage of the total circuit length is shown in Figure 1. The results show that the large majority of circuits are overhead. The proportion of circuits that are underground falls from 6.6% for the 50 to 109 kV range down to 0.5% for the 315-500 kV range.

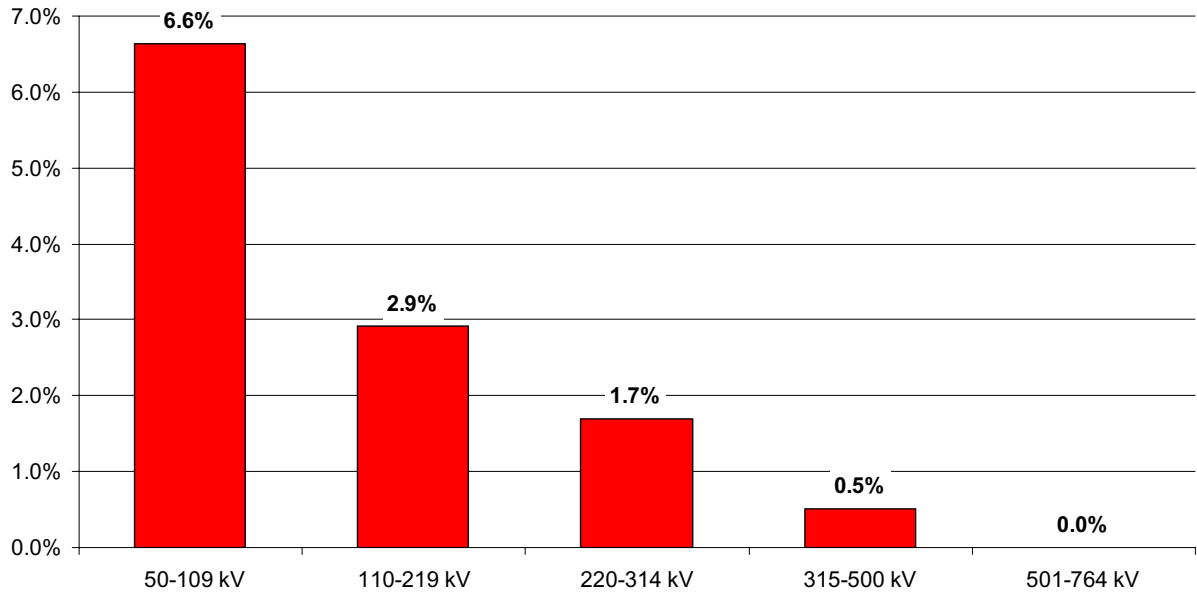

Figure 1: Percentage of the total circuit length that is underground for each of the 5 voltage levels

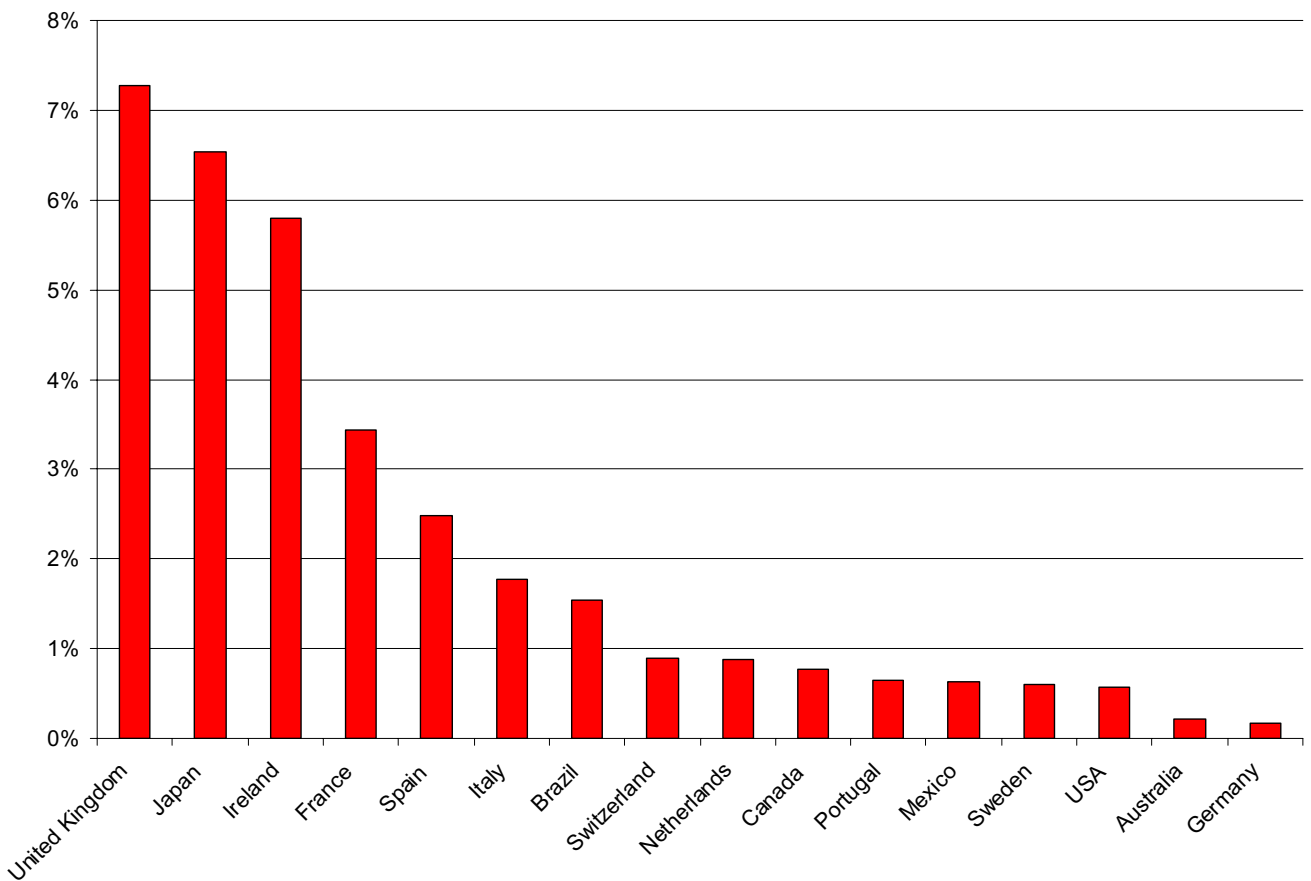

Figure 2: Percentage of the total ac circuit length underground in the 220 – 314 kV voltage range

The TB gives the circuit lengths installed in each country. As an example, Figure 2 shows the proportion of circuits that are underground in the 220 to 314 kV voltage level.

In order to simplify data collection, little technical detail was included in the questionnaire. However, where possible, respondents were asked to split the lengths of underground cable into those using lapped paper technologies and those using extruded polymeric insulation. The results are shown in Figure 3.

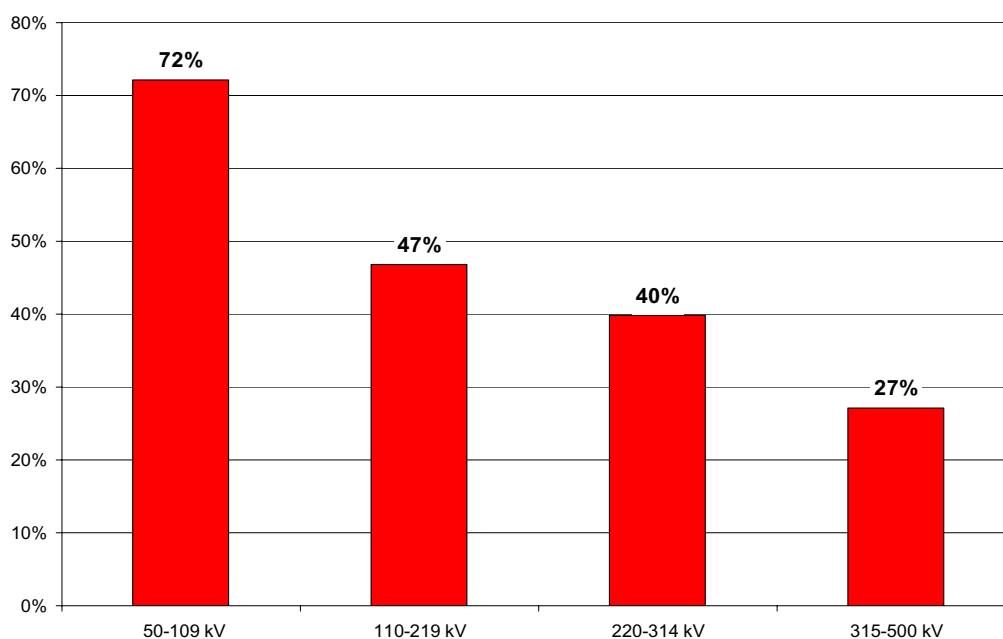

Figure 3: Percentage of the ac underground cable which has extruded polymeric insulation

The decreasing proportion of extruded insulation used at the higher voltages reflects the incremental development of these cables. Lower voltage, low stress cables were developed first and as the technology improved extruded insulation was applied to higher voltages and used at higher stress. 50 kV extruded cable has been in use since the early 1960s, whereas 400 kV and 500 kV transmission circuits using extruded insulation were not introduced until around 2000.

The data on installed lengths clearly show that utilities have a strong preference for overhead lines rather than underground cables. For the 50 kV to 109 kV range, 93% of the network is overhead. This value increases to 100% overhead at the 501-764 kV level.

## Technical Considerations

The factors which cause underground circuits to be technically more complex and hence generally more expensive than overhead lines are considered in Chapter 3, together with the reasons why this situation becomes worse at higher voltages.

Underground cables in transmission networks have generally been used in areas where it is not possible to use overhead lines. This is often because of space constraints (e.g. in



densely populated urban areas or within substations) or for technical reasons (e.g. for wide river and sea crossings). The preference for overhead lines is mainly on the grounds of cost and this driver becomes stronger as the voltage level increases.

The brochure describes the main technical differences between the underground and overhead transmission of bulk electric power under 3 inter-related headings:

- Electrical insulation of the conductor
- Heat transfer to prevent overheating
- Construction work necessary to install the circuit

Recent developments to reduce the cost differential between underground cables and overhead lines are also reviewed.

### Electrical Insulation

The overhead conductors of the transmission network are operated at a very high voltage with respect to earth or ground. These bare conductors are strung between steel towers which are usually set in concrete foundations. The surrounding air provides the necessary electrical insulation to earth.

When conductors are buried in the ground, insulating material must be applied to the conductors to allow them to operate safely at high voltage. Traditionally cables were insulated with oil impregnated paper, kept under pressure to maintain the integrity of insulation. More recently solid insulated cables have been developed predominantly using cross-linked polyethylene (XLPE) insulation. These became commonly used at voltages up to 60 kV in the 1960s and 70s. Development has continued steadily and this type of cable is now widely used, even at 400 and 500 kV.

### Heat transfer

A significant proportion of the additional cost and complexity of placing circuits underground results from the problem of removing waste heat from the cable.

For an overhead line conductor, energy is lost due mainly to the resistance of the conductor. The lost energy is converted to heat and is proportional to the square of the current flowing in the conductor.

An underground cable has this conductor loss, but also has additional losses due to currents induced in the sheath and to losses in the insulation. This loss is proportional to the square of the voltage on the cable and is present even if the cable is carrying no useful current.

For an overhead line, the surrounding air not only provides the necessary electrical insulation to earth but it also cools the conductors. In an underground cable, the electrical insulation will act as thermal insulation and impede the transfer of heat away from the conductor. The soil can present a significant thermal barrier, particularly if it is dry. It is

common practice to surround the cable with a specially selected backfill to enhance the dissipation of heat

An underground cable not only has additional sources of loss compared with an overhead line, but also has less effective heat dissipation. It is therefore important to keep the cable losses as low as possible, particularly for very high power circuits. This is often done by using a conductor of larger cross section than the equivalent overhead line, in order to reduce the electrical resistance. A further reduction can be obtained by using low resistivity copper for the conductor. (Overhead lines generally use aluminium alloy conductors to reduce the weight). Whilst the resulting underground cable has significantly lower resistance than its overhead counterpart, the use of a large copper conductor results in a cable conductor that is substantially heavier than that of the equivalent overhead line.

It is more efficient to transmit large quantities of electric power at higher voltages. A single 400 kV overhead line can replace a large number of lower voltage lines. Thus the use of the 400 kV line offers significant advantages (both economic and visual). However, the concentration of power down a single route has two important consequences for very high voltage circuits. Firstly, they must be extremely reliable. Interruption to the supply would affect either a large number of domestic customers or some very large industrial users of electricity. Secondly, the large power transfer is accompanied by the production of a significant amount of 'waste' heat confined to a single route.

The combined requirements of extremely high reliability and good heat dissipation mean that as the power and voltage of a cable increase, so does its size and the complexity of construction works.

### Construction and Installation

Putting the cables underground is a significant part of the cost of a project. The cost varies widely depending on the ease of access along the route and the amount of power to be transmitted. The TB describes how the need for adequate heat dissipation determines the size and spacing of trenches and the overall extent of construction work.

In urban areas, the costs of cable installation tend to be significantly higher than in the countryside. In the city, there are likely to be a large number of crossing services, for example gas, water and telecommunications. This restricts the use of mechanical diggers and parts of the trench have to be dug by hand. The trench walls usually have to be supported in order to work safely. Additional costs arise from the need to manage the traffic flow and from the restrictions often placed on the hours of working in order to reduce inconvenience to local residents. For minimum disruption, cables can be installed in deep bored tunnels. This is an expensive method, but in major cities it is sometimes the only practical option.

In rural or open areas, the costs of cable installation are likely to be reduced. A mechanical excavator can often be used to dig the trench and there may be sufficient space and suitable soil conditions to dig a trench with unsupported sloping walls.

There may be significant additional costs with large-scale rural undergrounding in order to preserve the natural environment (for example watercourses, hedgerows and woodlands). Special techniques such as directional drilling may be used for crossings under roads, railways and waterways.

### Electrical Design

The electrical design of underground systems is briefly described. Aspects covered include: fault clearance and protection, special bonding, and reactive compensation.

### Operation

There are significant differences in the way in which underground cables and overhead lines affect the operation of the power system in areas such as: security of supply, fault repairs, routine maintenance and safety.

### Reducing the cost of undergrounding

A number of techniques are being used in an attempt to reduce the cost differential between underground cables and overhead lines.

Improvements in cable design are leading to lighter cable and hence longer drum lengths, leading to reduced cost and shorter installation times. The cost of installation can be reduced by the use of mechanised laying techniques, particularly for low power cables in rural environments.

There may be circumstances in which a cable has to be connected to an overhead line whose rating is far greater than the present day need. It may be economic to install a cable that meets the present day requirements and then install a second cable per phase once the load has grown sufficiently. For a ducted cable system it may be more economic to install spare ducts during civil work for the initial installation

Temperature measurement and real-time rating techniques also provide an option for deferring expenditure by extending the time for which the existing cable meets the need.

## **Cost Factors**

Chapter 4 examines how to evaluate the cost of underground transmission circuits and how to compare these with overhead systems

## Cost Ratios

Cost ratios are often thought of as simple way of comparing costs, for example saying an underground cable is 10 times as expensive as overhead line. In reality there can be a wide range of values quoted for apparently similar circuits and this leads to confusion and mistrust between the various stakeholders.

Small changes in the design of the circuit can produce large changes in cost ratios and, in financial terms, the ratios have little meaning. It is the added cost of undergrounding that is important and must be weighed against the benefits (largely visual) that it brings.

In the 1996 study, the Joint Working Group tried to gather international values for cost ratios, but as might be expected the results were of limited use. For circuits operating at voltages between 220 kV and 362 kV, cost ratios ranged between 5 and 21. The quoted ratios vary widely, because they are highly dependent on local circumstances (including terrain, land costs and power flows).

The present WG considered the option of collecting international costs for a well-defined 'typical' cable circuit, but it is even difficult to obtain international consensus on what might constitute a 'typical' cable circuit. We concluded that it is not possible to collect a consistent set of data for overhead and underground costs that would give more reliable cost ratios than those obtained in 1996.

The only reliable method of comparing overhead and underground costs is on a case by case basis. Generic values of cost ratio are of very limited use and should be avoided. Estimates for the costs of underground and overhead options for a specific project must be calculated and then weighed against the advantages and disadvantages of each option.

## Components of cost for cable systems

Costs can be estimated for the various stages of the cable's lifecycle:

- Planning/Design
- Procurement
- Construction
- Operation
- End of Life

In general the early capital costs, particularly procurement and construction, are usually found to be the most significant. They are immediate and tend to be larger than later costs such as repair and maintenance and hence have most effect on the financing of projects.

Later costs can be very difficult to estimate. It is particularly difficult to estimate both the magnitude and the cost of future electrical losses. The magnitude of losses are highly dependent on how heavily the line will be loaded and the cost of the losses depends on

factors such as the cost of fuel and the availability of surplus generation capacity. None of these factors are easy to estimate even in the short-term. Estimating their likely values in 40 years' time is extremely difficult, particularly in a deregulated environment

By analysing the underground cable costs for each stage of the cable's life, it is easier to assess which costs are important and which estimates are least reliable. A similar methodology can be used to estimate the cost of the equivalent overhead line.

### Comparing underground and overhead options

The only reliable way of comparing the costs of underground and overhead options is on a case by case basis. There is no general answer to how the costs compare. In Chapter 3, technical options for reducing the cost of undergrounding were discussed. These often involve a willingness to be flexible in the design of installations rather than just accepting a standard design solution. This in itself makes the concept of a standard cost for a circuit untenable.

Historic values of underground and overhead costs are often a poor guide to present day costs. The price of underground cable is strongly influenced by fluctuations in the commodity price of raw materials such as copper. It is also expensive to manufacture and store large stocks of cable, particularly for the very high voltages. In consequence the price of underground cable is very sensitive to the balance between demand and manufacturing capacity.

The other problem with using historic values of underground and overhead costs is that underground cable has traditionally been used mainly in the centres of towns and cities with overhead lines being used for rural transmission circuits. There has therefore been a tendency to compare the cost of urban underground cable with that of rural overhead line, which may give an inaccurate comparison.

For each project, the costs of underground and overhead options must be calculated and these can then be compared. Once the cost difference has been calculated, this can be compared with those benefits and threats which are more difficult to express in monetary terms. These include factors such as visual intrusion, threats to sensitive habitat and damage to archaeological heritage.

There are also land-use issues which need to be considered, where the installation of an overhead or underground line might restrict future options for either agriculture or suburban building development.

Factors such as visual intrusion and threats to sensitive habitat are not generally the same along the whole route. In some cases partial undergrounding is an opportunity for compromise. However, the transition from overhead to underground can have significant impact on the local environment and adjacent short sections of undergrounding are unlikely to be desirable.

However even that generalisation may be unwise without considering the details of a specific case. Only by calculating the cost differential between underground and overhead options for a particular circuit can this be weighed against the other benefits and threats to give a rational basis for a decision.

## **Conclusions**

Chapter 5 summarises the WG's conclusions.

The data on installed lengths clearly show that utilities have a strong preference for overhead lines rather than underground cables. For the 50 kV to 109 kV range, 93% of the ac network is overhead, increasing to 100% overhead at the 501-764 kV level.

Cost ratios are volatile; in particular, they are highly sensitive to small changes in overhead line cost and as a result they must be used with extreme caution.

Small changes in the design of the circuit can produce large changes in cost ratios and, in financial terms, the ratios have little meaning. It is the added cost of undergrounding that is important and must be weighed against the benefits (largely visual) that it brings.

In the 1996 study cost ratios ranging between 5 and 21 were quoted for circuits operating at voltages between 220 kV and 362 kV. The quoted ratios vary widely, because they are highly dependent on local circumstances (including terrain, land costs and power flows). The present WG concluded that it is not possible to collect more reliable cost ratios than those obtained in 1996.

The only reliable method of comparing overhead and underground costs is on a case by case basis and generic values of cost ratio are of very limited use and should be avoided. Estimates for the costs of underground and overhead options for a specific project must be calculated and then weighed against the advantages and disadvantages of each option.

Once the cost difference has been calculated, this can be compared with those benefits and threats which are more difficult to express in monetary terms. These include factors such as visual intrusion, threats to sensitive habitat and damage to archaeological heritage. There are also land-use issues which need to be considered, where the installation of an overhead or underground line might restrict future options for either agriculture or suburban building development.

Factors such as visual intrusion, threats to sensitive habitat, etc. are not generally the same along the whole route. In some cases partial undergrounding is an opportunity for compromise, but the transition from overhead to underground can have significant impact on the local environment and adjacent short sections of undergrounding are unlikely to be desirable.

Underground cable systems are often tailored to meet specific local conditions, but the same solution may not be applicable elsewhere. Hence, even for the same voltage and

power, the costs of an underground cable system can vary widely. This makes it difficult to generalise the cost of a typical underground cable system.

Only by calculating the cost differential between underground and overhead options for a particular circuit can this be weighed against the other benefits and threats giving a rational basis for a choice between overhead and underground transmission.

# 1 Introduction

In the mid 1990s CIGRE Study Committees 21 (HV Cables) and 22 (Overhead lines) set up a Joint Working Group to compare high voltage overhead transmission lines and underground cables. The report [1,2] examined the extent to which the two systems were used worldwide and the cost implications. In 2003 CIGRE Study Committee B1 decided that a new working Group (WG B1-07) be set up to update the work done in the 1990s.

The terms of reference of WG B1-07 are:

- To collect statistics for the lengths of underground and overhead circuits at a range of transmission voltages. Only existing lines and projects planned for implementation by 2006 should be included,
- To describe significant underground cable projects realised in the period 1996-2006 giving the reasons why undergrounding was selected,
- To describe the factors which must be considered when evaluating the cost of overhead or underground connections,
- To describe the other factors which must be taken into account in order to make a balanced choice between overhead and underground technology.

Submarine cables are excluded from the scope of work. DC cables are also excluded since these are predominantly submarine. The voltage range is restricted to system voltages from 50 kV, which limits the scope to transmission systems and the high end of the distribution voltage range.

Some significant changes have taken place since the 1996 report was published. A number of weather-related incidents on overhead lines have led some utilities to revise their meteorological design parameters leading to increased costs. Technical changes and strong competition in the cable sector have reduced prices. Increased urbanisation and public concerns have increased the difficulty and time taken to obtain consents for overhead lines. There have been broad changes in the structure of electricity supply and in the nature of demand, for example the load peak in some countries or regions is shifting from winter to summer. In view of these changes WG B1-07 has updated the statistics on circuit lengths and produced guidance on the technical and cost factors influencing the choice between underground cable and overhead line.

Chapter 2 of this Brochure describes collection and analysis of data on the lengths of underground cable and overhead line currently installed.

Chapter 3 looks at some of the main technical factors which influence the cost and complexity of underground transmission systems.



Chapter 4 examines how to evaluate the cost of underground transmission circuits and how to compare these with overhead systems

Chapter 5 summarises the Working Group's conclusions.

Chapter 2 to 4 represent a high level overview of information on the topics considered. Further technical details are included in the Appendices A to F.

Appendix G describes some significant cable projects that have been undertaken in the last 10 years. Table G1 gives an overview of significant underground cable projects constructed since 1996, arranged in order of decreasing voltage and conductor size. The table summarises where and when the cables were installed and gives brief details of the cable design and the installation method. Table G2 shows the projects arranged in order of country and geographical location

Some of the most significant projects are then described in more detail. Table G3 serves as an index to these brief project descriptions.

The definition of a significant cable project is difficult. The Working Group decided that it is a cable project at 50 kV or above, which is likely to be of broad international interest and containing some element of innovation. The project can be significant in engineering, commercial, environmental or social terms.

The brief project descriptions give basic details of the cable type, installation methods and the reasons for their choice. Details of the power carrying capability (rating) are generally included together with information on why underground cable was selected rather than overhead line.

In this Brochure the term 'cable' is used exclusively to refer to an underground cable and the term 'line' always means an overhead line.

## 2 Statistics of installed lengths

Data on the lengths of ac underground cable and overhead line currently installed were collected by means of a questionnaire sent to Study Committee members. The statistics were divided in to five voltage ranges:

- 50-109 kV
- 110-219 kV
- 220-314 kV
- 315-500 kV
- 501-764 kV

These voltage ranges were chosen in order to group together similar design and operational principles as far as possible.

The data were collated and wherever possible, checked for consistency. Full details on data collection and analysis are given in Appendix A.

In some cases, data capture proved difficult, particularly for countries which have a multitude of small independent utilities (for example the USA and Germany). In addition, the national systems for maintaining such data have been discontinued in some countries, as utilities have been released from state control and experienced reorganisation, merger and acquisition. Where it was not possible to collect data from all utilities in a country this is noted in Appendix A and care was taken to ensure that data were collected from a representative sample of utilities and to include data for the largest utilities.

The data were collected in 2005 and 2006, but utilities were asked to include any circuits that were under construction and would be completed by December 2006. All values reported here are the total lengths of ac overhead line or cable circuits installed on the network and not the increase in length since the 1996 report.

Table 2.1 shows the lengths of ac overhead line installed in some large networks (countries reporting greater than 20000 km of overhead line). Table 2.2 shows the lengths of ac underground cable installed by major users (countries reporting greater than 1000 km of underground cable). The results for all countries surveyed are given in Appendix A.

The length of underground cable circuit expressed as a percentage of the total circuit length is given in Table 2.3 for each country. The international totals for each voltage range are shown in Figure 2.1. The results show that the large majority of circuits are overhead. The proportion of circuits that are underground falls from 6.6% for the 50 to 109 kV range down to 0.5% for the 315-500 kV range.

Table 2.1: Total length of ac overhead line (circuit km) currently installed on large networks (countries reporting greater than 20000 km of overhead line)

Country	50-109 kV	110-219 kV	220-314 kV	315-500 kV	501-764 kV
Australia	2153	13188	7151	6734	
Brazil	2735	9103	1405	6799	
Canada	6849	24342	19786	12847	11422
Finland		15300	2400	4000	
France	48835	1064	25416	21007	
Germany	13156	76630	26790	18200	
Italy	40	38278	10924	10651	
Japan	67989	34732	20594	15879	
Korea	993	16813		7563	662
Mexico	3450	44323	26500	19000	
Poland		32227	8119	4830	114
Romania		25909	5550	4389	86
Spain	10697	12220	18757	18806	
Sweden	4265	14356	4417	10620	
United Kingdom	3073	23192	6321	11122	
USA	165830	315309	116890	122176	4406

Table 2.2: Total length of ac underground cable (circuit km) currently installed on the networks of major users (countries reporting greater than 1000 km of underground cable)

Country	50-109 kV	110-219 kV	220-314 kV	315-500 kV
Denmark	1930	515		52
France	2316	1	903	2
Germany	857	4972	45	65
Italy	0	907	197	34
Japan	11760	1769	1440	123
Korea	2	2144		221
Netherlands	2558	1068	6	7
Singapore	1185		651	111
Spain	509	181	479	80
United Kingdom	1457	2967	496	166
USA	946	2904	663	536

Table 2.3: Length of ac underground cable circuit expressed as a percentage of the total ac circuit length installed.

	50-109 kV	110-219 kV	220-314 kV	315-500 kV	501-764 kV
Australia	4.2	1.5	0.2	0.9	
Austria		6.9	0.1	2.2	
Belgium	8.0	7.6	0.0	0.0	
Brazil	0.2	0.0	1.5	0.8	
Canada	0.9	1.6	0.8	0.1	0.0
China		27.0	8.6	0.0	
Croatia		1.1	0.0	0.0	
Denmark	24.3	12.4	0.0	3.8	
Finland		1.8	0.0	0.0	
France	4.5	0.1	3.4	0.0	
Germany	6.1	6.1	0.2	0.4	
Ireland		3.6	5.8	0.0	
Israel		2.2		0.0	
Italy	0.0	2.3	1.8	0.3	
Japan	14.7	4.8	6.5	0.8	
Korea	0.2	11.3		2.8	0.0
Mexico	3.6	1.3	0.6	0.0	
Netherlands	89.9	16.3	0.9	0.3	
New Zealand	0.7	2.0	0.0		
Poland		0.2	0.0	0.0	0.0
Portugal	5.0	0.1	0.6	0.0	
Romania		1.1	0.1	0.0	0.0
Singapore	100		100	100	
Spain	4.5	1.5	2.5	0.4	
Sweden	2.6	2.3	0.6	0.1	
Switzerland	13.5	25.3	0.9	0.0	
United Kingdom	32.2	11.3	7.3	1.5	
USA	0.6	0.9	0.6	0.4	0.0

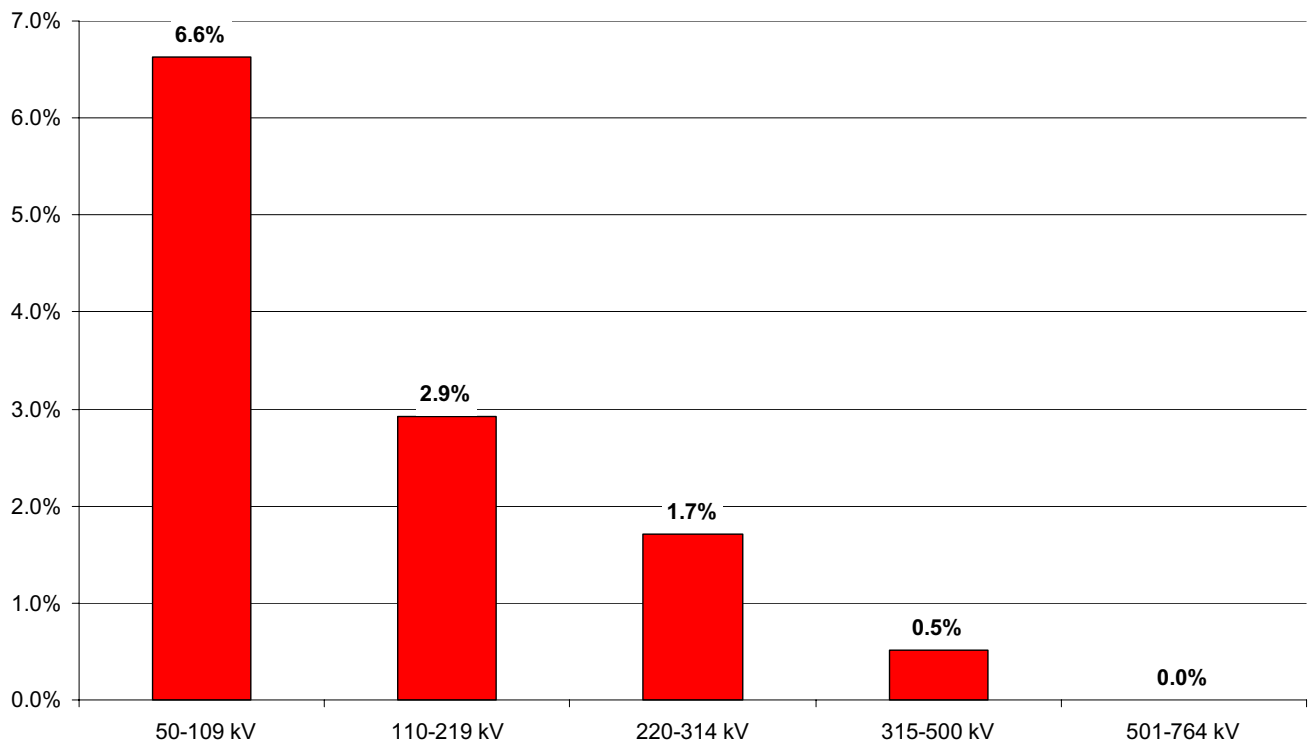

Figure 2.1: Percentage of the total ac circuit length that is underground for each of the five voltage levels

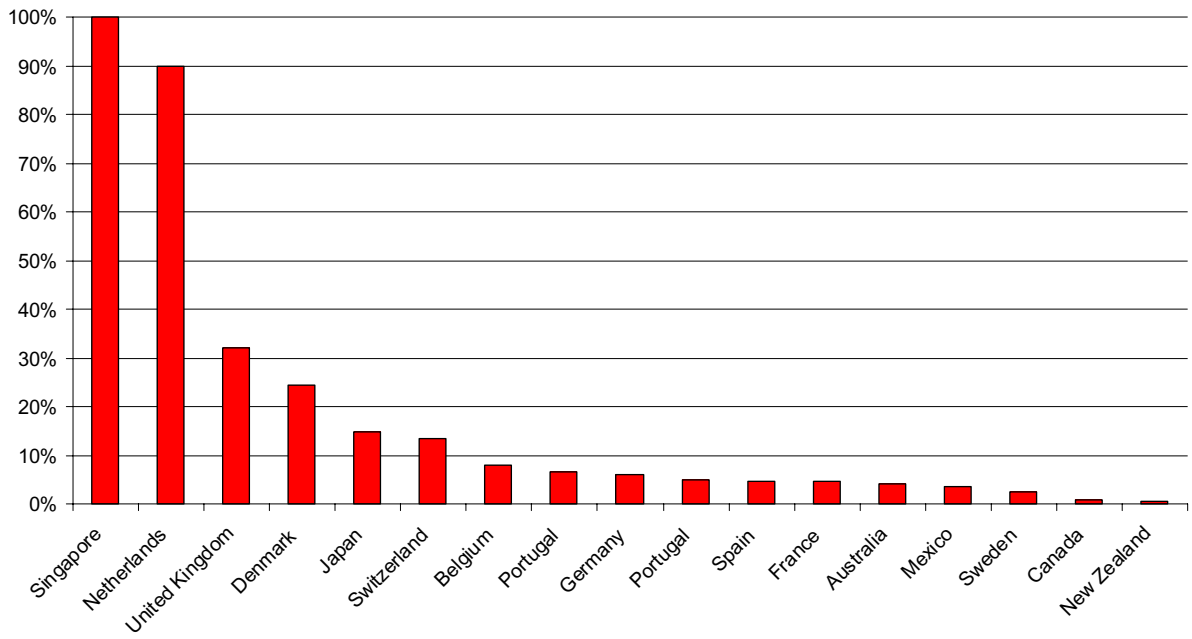

Figure 2.2: Percentage of the total ac circuit length underground at the 50 – 109 kV voltage level

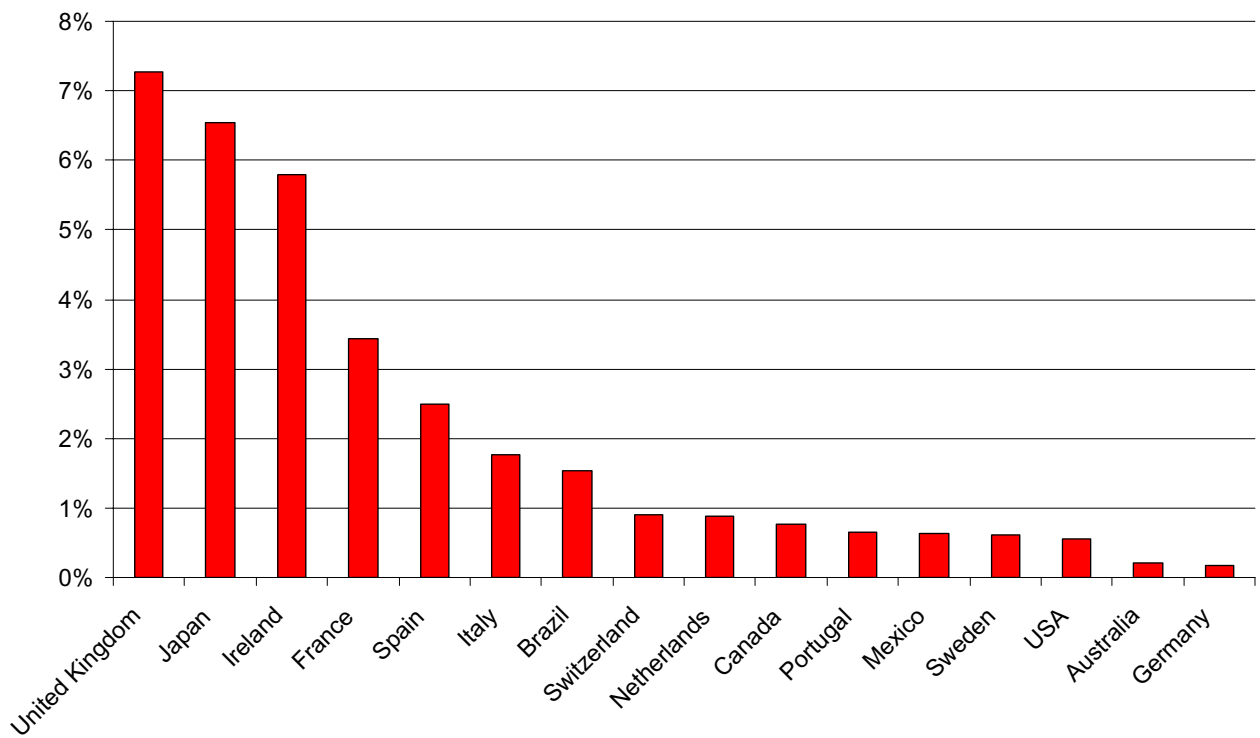

Figure 2.3: Percentage of the total ac circuit length underground at the 110 – 219 kV voltage level

Figure 2.2 shows the national percentages of total circuit length underground at the 50 kV to 109 kV voltage level. The data for the 110 kV to 219 kV range is shown in Figure 2.3.

Certain geographical areas have such high population density and such high land values that it is difficult to find suitable overhead line routes, for example central Paris and Hong Kong island. Singapore is another example, which covers an entire country. Data for Singapore is omitted from Figure 2.3 as it does not have a network voltage in the 110 kV to 219 kV range and from Figures 2.4 and 2.5 where the Singapore data (100% cable) would mask other features.

Figures 2.4 and 2.5 show the national percentages of circuit length underground at the 220 – 314 kV and 315 – 500 kV voltage levels respectively. There is no significant length of underground transmission at the 501-764 kV level.

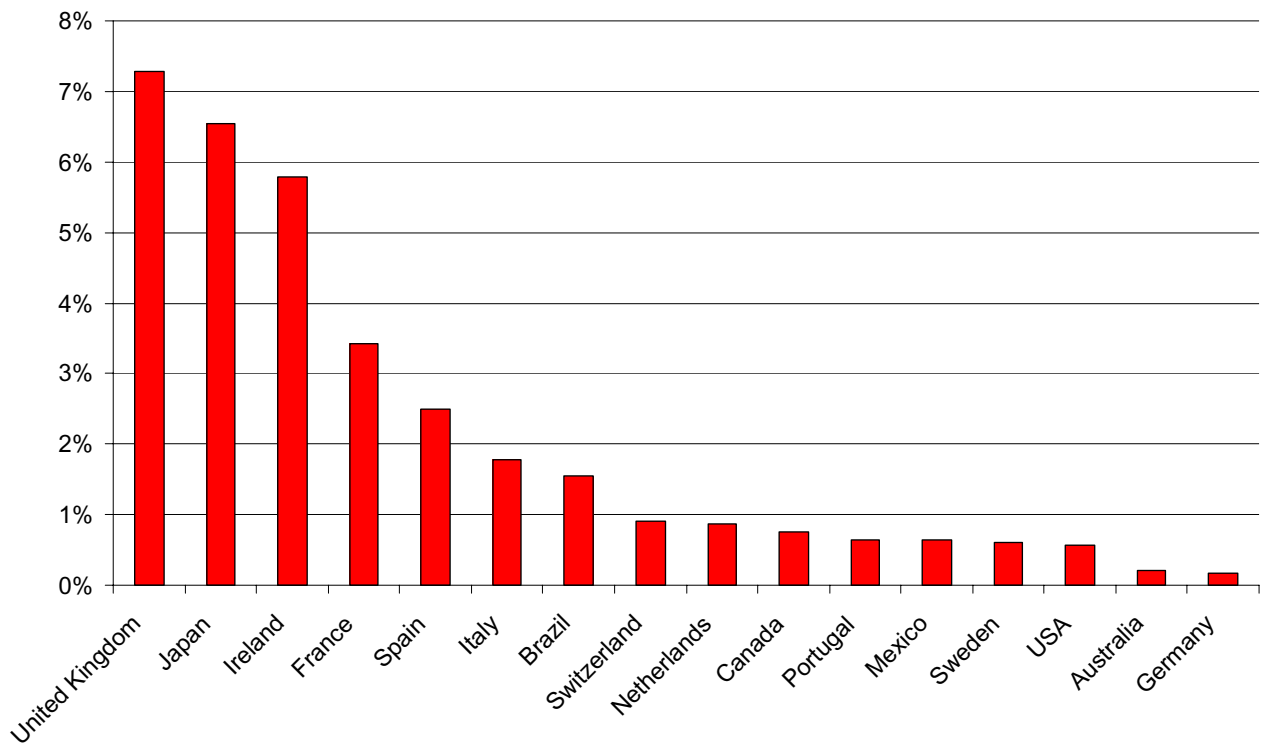

Figure 2.4: Percentage of the total ac circuit length underground at the 220 – 314 kV voltage level

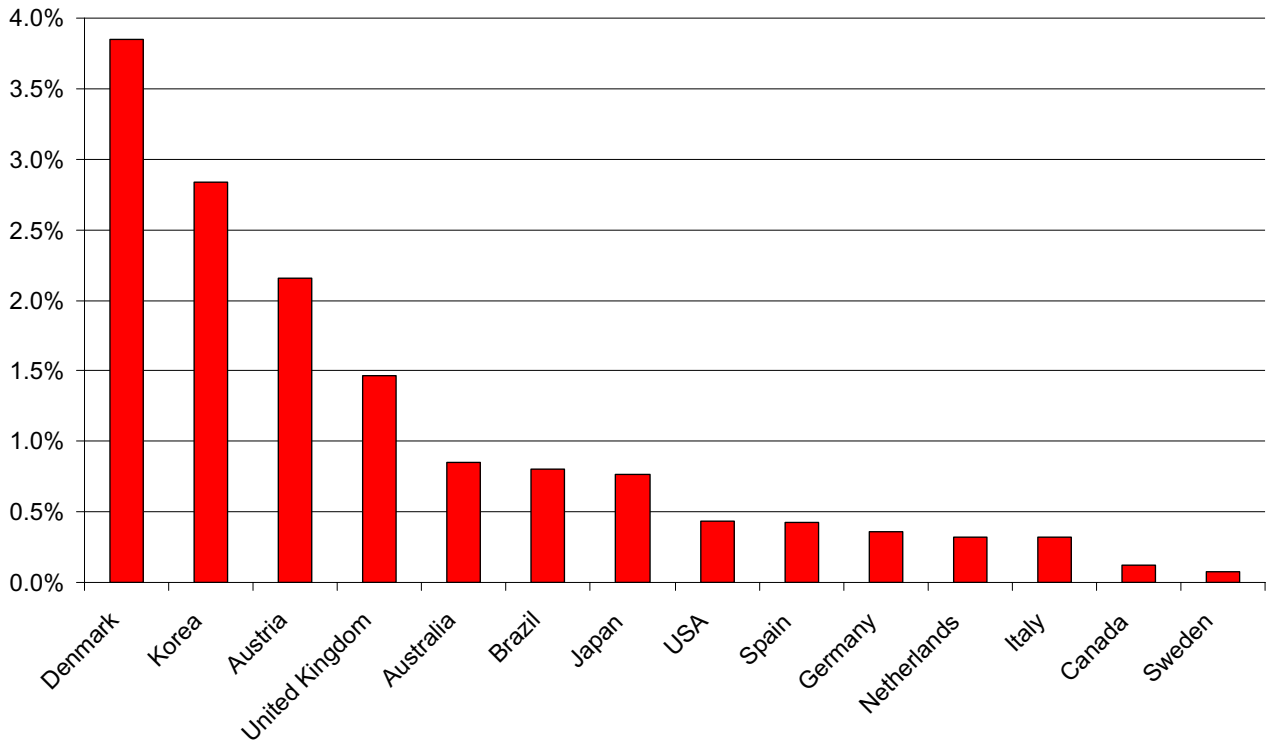

Figure 2.5: Percentage of the total ac circuit length underground at the 315 – 500 kV voltage levels

In order to simplify data collection, very little technical detail was included in the questionnaire. However, where possible, respondents were asked to split the lengths of underground cable into those using lapped paper technologies and those using extruded polymeric insulation. The results are shown in Figure 2.6.



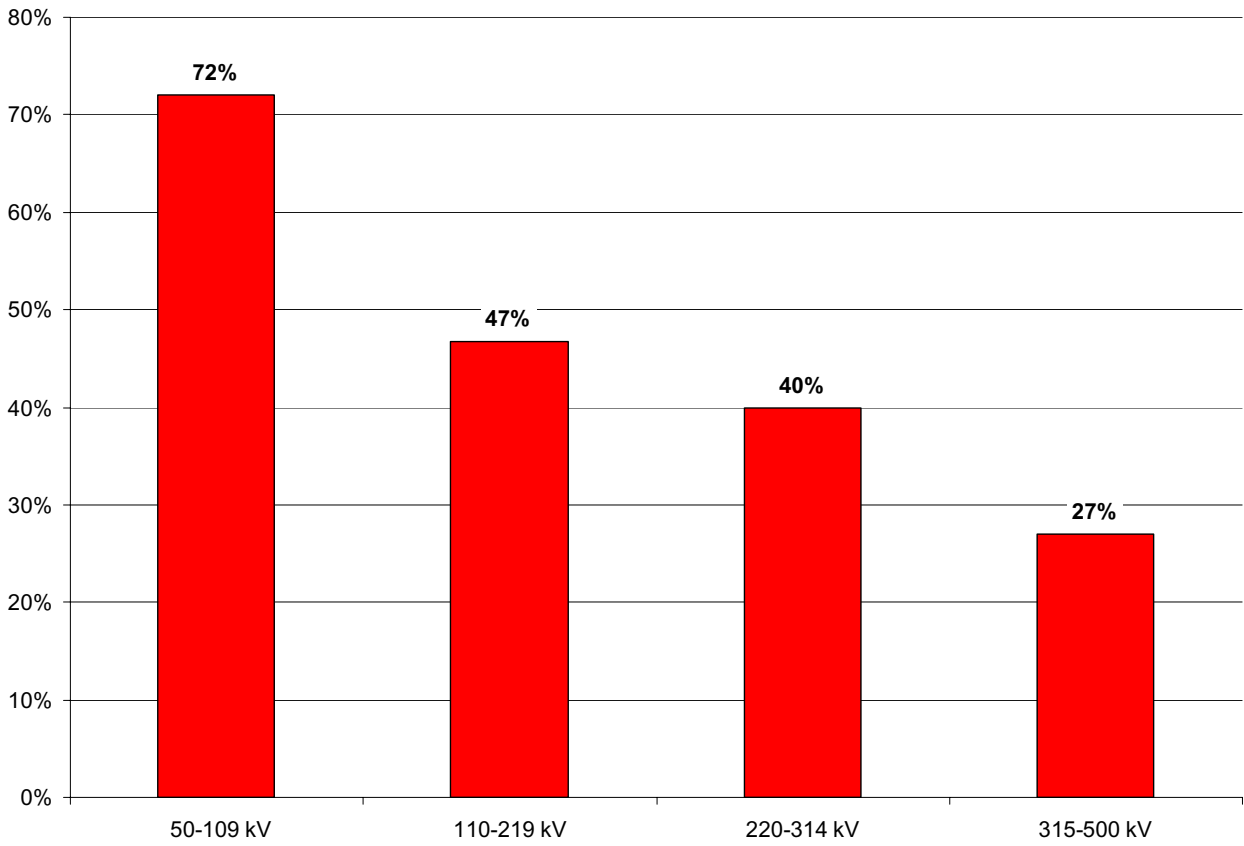

Figure 2.6: Percentage of the ac underground cable having extruded polymeric insulation

The decreasing proportion of extruded insulation used at the higher voltages reflects the incremental development of these cables. Lower voltage, low stress cables were developed first and as the technology improved extruded insulation was applied to higher voltages and used at higher stress. 50 kV extruded cable has been in use since the early 1960s, whereas 400 kV and 500 kV transmission circuits using extruded insulation were not introduced until around 2000.

The data on installed lengths clearly show that utilities have a strong preference for overhead lines rather than underground cables. For the 50 kV to 109 kV range, 93% of the network is overhead. This value increases to 100% overhead at the 501-764 kV level.

The factors which cause underground circuits to be technically more complex and hence generally more expensive than overhead lines are considered in Chapter 3, together with the reasons why this situation becomes worse at higher voltages.

### 3 Technical Considerations

Underground cables in transmission networks have generally been used in areas where it is not possible to use overhead lines. This is often because of space constraints (e.g. in densely populated urban areas or within substations) or for technical reasons (e.g. for wide river and sea crossings). The preference for overhead lines is mainly on the grounds of cost and this driver becomes stronger as the voltage level increases. This Chapter examines the technical reasons for the higher cost of underground circuits.

The main technical differences between the underground and overhead transmission of bulk electric power can be considered under 3 inter-related headings:

- Electrical insulation of the conductor
- Heat transfer to prevent overheating
- Construction work necessary to install the circuit

This Chapter also considers the main differences in electrical design and system operation between underground cables and overhead lines. Recent developments to reduce the cost differential between underground cables and overhead lines are also reviewed.

#### 3.1 *Electrical Insulation*

The overhead conductors of the transmission network are operated at a very high voltage with respect to earth or ground. These bare conductors are strung between steel towers which are usually set in concrete foundations. If the tower forms part of a straight portion of line, the conductors are attached to insulators suspended from the tower crossarm. Where the overhead line deviates from a straight line, strengthened angle towers are used and the conductors are tensioned to insulators in a horizontal formation. The component parts of a 400 kV overhead line system are shown in figure 3.1. The surrounding air provides the necessary electrical insulation to earth. Figure 3.2 shows a single circuit supported on a double wood pole, which can be used at the lower transmission voltages such as 110 kV

When conductors are buried in the ground, insulating material must be applied to the conductors to allow them to operate safely at high voltage. Traditionally underground cables were insulated with oil impregnated paper (figure 3.3). The oil, carried into the cable by a central oil duct, must be kept under pressure to maintain the high level of insulation. Other types of paper cable are high pressure fluid filled cables known also as Pipe Type cables, where the three phases of the cable are contained in a steel pipe that is pressurized with either nitrogen or oil to improve the dielectric properties.

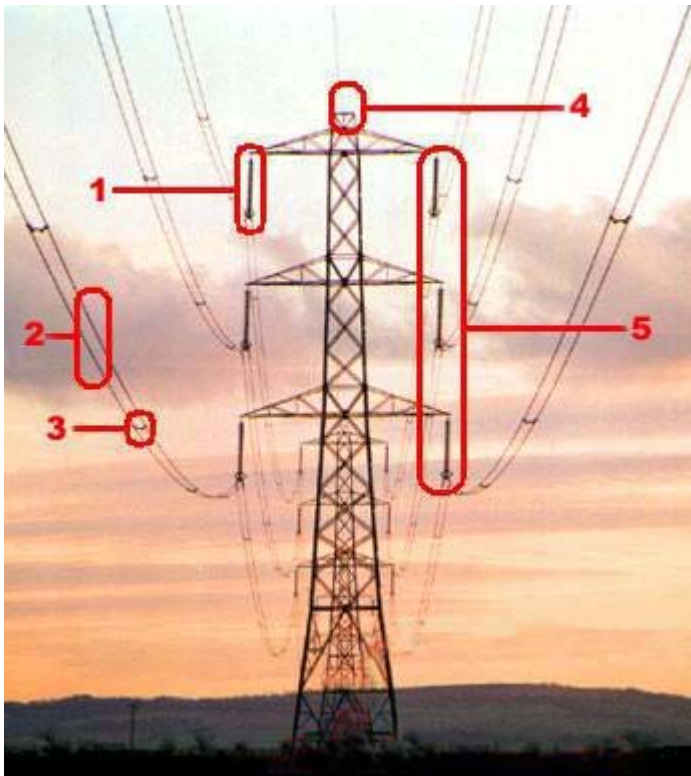

- (1) Insulator
- (2) Phase conductor  
low-power lines often have a single conductor; higher power lines may use multiple sub-conductors.
- (3) Spacer to hold the two sub-conductors apart
- (4) Earth wire at the top of the tower or pylon
- (5) The three phase conductors on one side of the tower make up one electrical circuit. Most lines have two circuits, one on each side.

Figure 3.1: Components of a 400 kV overhead line on a steel lattice tower



Figure 3.2: Single circuit overhead line supported on double wood poles

More recently solid insulated cables have been developed using polyethylene-based insulation, now mainly cross-linked polyethylene (XLPE) cable. These became commonly used at voltages up to 60 kV in the 1960s and 70s. Development has continued steadily and this type of cable is now widely used, even at 400 and 500 kV. The conductor and its electrical insulation must be protected against damage, moisture and deterioration. This is provided by an outer metallic sheath (usually of aluminium, copper or lead).

The sheath system also serves as part of the electrical screen of the cable and often includes wires to assist in conducting current safely to earth should a fault develop in the cable system. This sheath is further protected against mechanical damage and corrosion by a final covering of tough plastic. Figure 3.4 shows the structure of a cross-linked polyethylene cable.

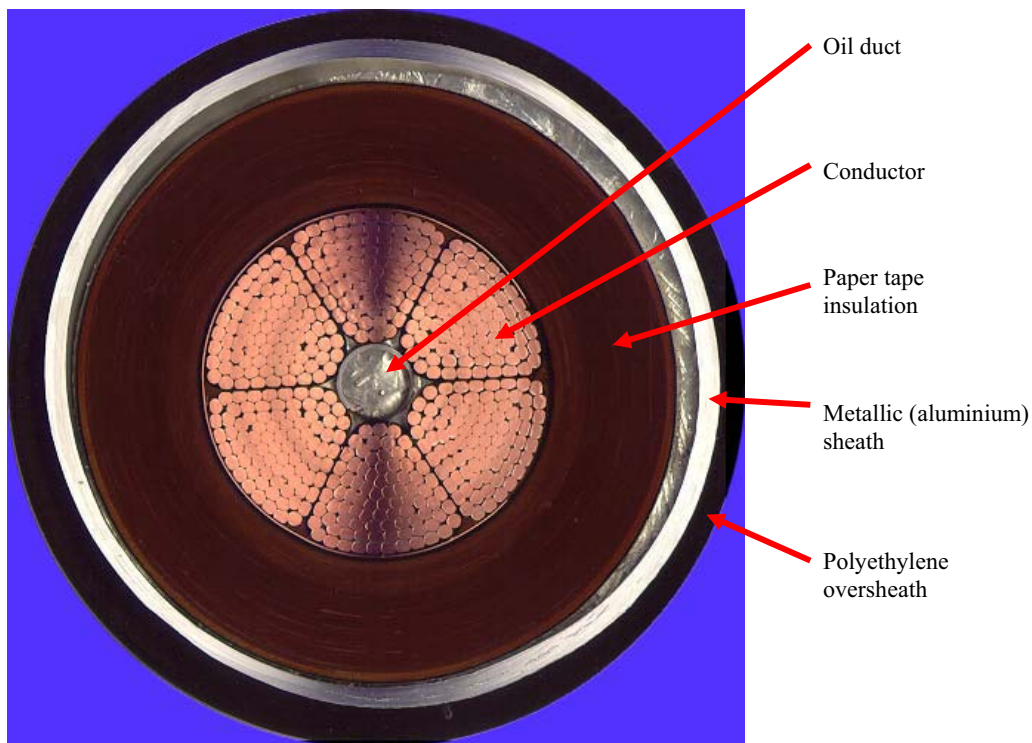

Figure 3.3: Structure of an oil-filled cable

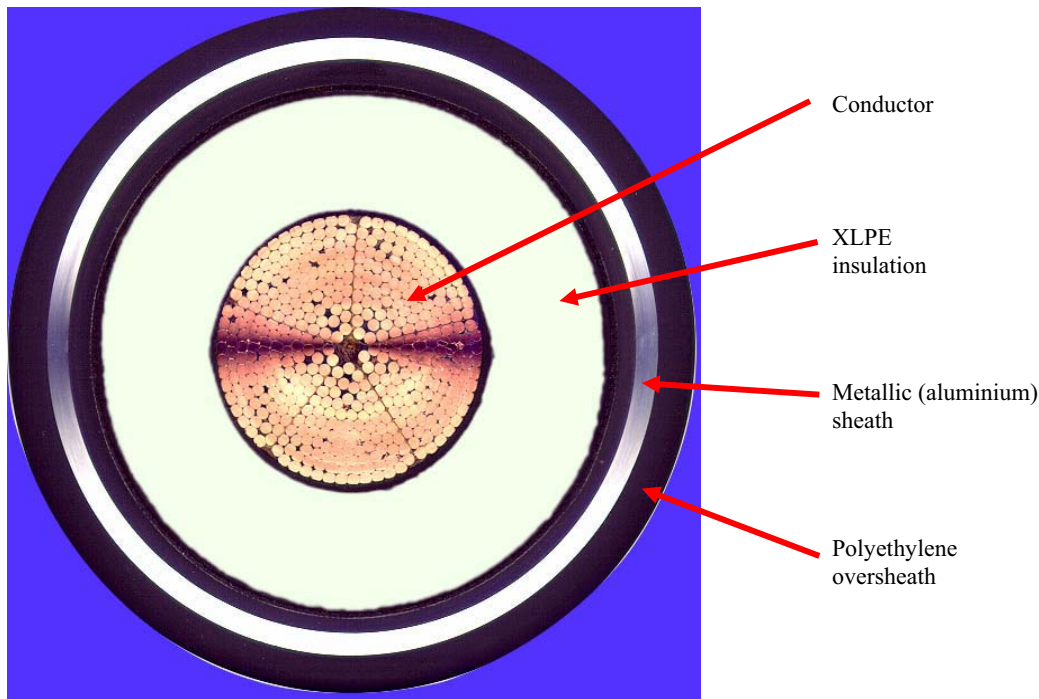

Figure 3.4: Structure of a cross-linked polyethylene cable.

### 3.2 *Heat transfer*

A significant proportion of the additional cost and complexity of placing circuits underground results from the problem of removing waste heat from the cable.

For an overhead line conductor, energy is lost due mainly the resistance of the conductor. The lost energy is converted to heat and is proportional to the square of the current flowing in the conductor.

An underground cable also has this conductor loss, but also has additional losses due to currents induced in the sheath and to losses in the insulation (or dielectric). The dielectric loss is proportional to the square of the voltage on the cable. This loss is present even if the cable is carrying no useful current (or load). For this reason the dielectric loss is sometimes referred to as the no-load loss.

In order to prevent degradation of the cable insulation, it is designed to operate at temperatures up to 90°C. Overhead line conductors generally operate to similar temperatures, but in this case the limit is defined by the need to restrict the extent to which the conductor sags (due to thermal expansion) in order to prevent safety clearances being infringed. At 400 kV a typical minimum clearance to a road surface is about 8 m.

For an overhead line, the surrounding air not only provides the necessary electrical insulation to earth but it also cools the conductors. In an underground cable, the electrical

insulation also acts as thermal insulation and impedes the transfer of heat away from the conductor. The heat generated by the various losses in the cable has to pass through the cable structure (figure 3.5) into the soil and out to the atmosphere. The soil can present a significant thermal barrier, particularly if it is dry. It is common practice to surround the cable with a specially selected backfill to enhance the dissipation of heat (see Section 3.3).

An underground cable not only has additional sources of loss compared with an overhead line, but also has less effective heat dissipation. It is therefore important to keep the cable losses as low as possible, particularly for very high power circuits. This is often done by using a conductor of larger cross section than the equivalent overhead line, in order to reduce the electrical resistance. A further reduction can be obtained by using low resistivity copper for the conductor. Overhead lines generally use aluminium conductors to reduce the weight. Whilst the resulting underground cable has significantly lower resistance than its overhead counterpart, the use of a large copper conductor results in a cable conductor that is substantially heavier than that of the equivalent overhead line. Table 3.1 compares the weight, diameter and electrical resistance of overhead conductor and underground cable of similar capacity. To obtain a similar transmission capacity (rating) it is necessary to use a 2500 mm<sup>2</sup> copper underground cable conductor to match an 800 mm<sup>2</sup> aluminium alloy overhead line. The relative sizes of the two systems are shown in Figure 3.6. Further technical details on the thermal ratings of cable and overhead lines are given in Appendix B.

Table 3.1 Characteristics of overhead conductor and underground cable of similar rating. (The details of the conductor used in the underground cable are included for comparison)

	Material	Area (mm <sup>2</sup> )	Diameter (mm)	Mass per unit length (kg/m)	Resistance (Ω/km)
Overhead conductor	Aluminium alloy	821	37.3	2.3	0.039
Underground conductor only	Copper	2500	64	22	0.007
Complete underground cable			149	39	

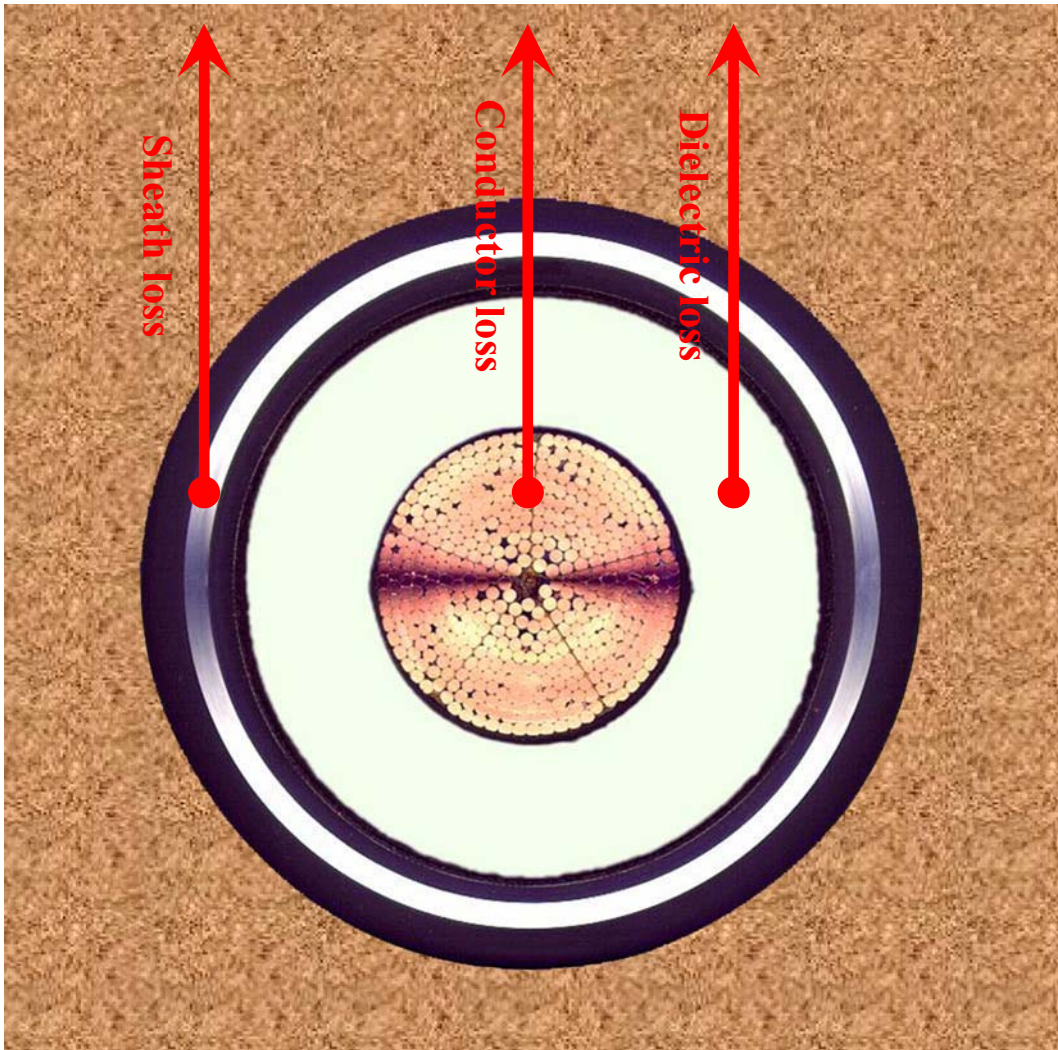

Figure 3.5: Losses produced by an underground cable

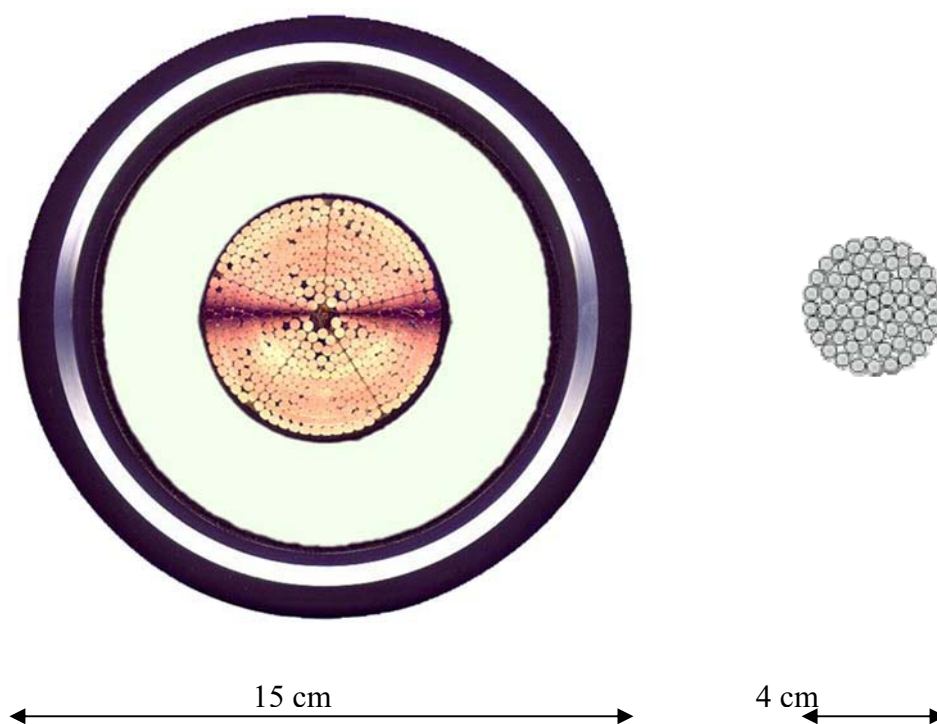

Figure 3.6: Relative size of a 400 kV XLPE cable and an overhead line conductor of similar rating

In general the higher the voltage at which an electrical circuit operates, the larger is the power that it can transmit. Figure 3.7 shows the average rating of circuits reported by utilities responding to our questionnaire.

It is more efficient to transmit large quantities of electric power at higher voltages. A single 400 kV overhead line can replace a large number of lower voltage lines. Thus the use of the 400 kV line offers significant advantages (both economic and visual). However, the concentration of power down a single route has two important consequences for very high voltage circuits. Firstly, they must be extremely reliable. Interruption to the supply would affect either a large number of domestic customers or some very large industrial users of electricity. Secondly, the large power transfer is accompanied by the production of a significant amount of ‘waste’ heat confined to single route.

The following section shows how the combined requirements of extremely high reliability and good heat dissipation mean that as the power and voltage of a cable increase, so does its size and the complexity of construction works.



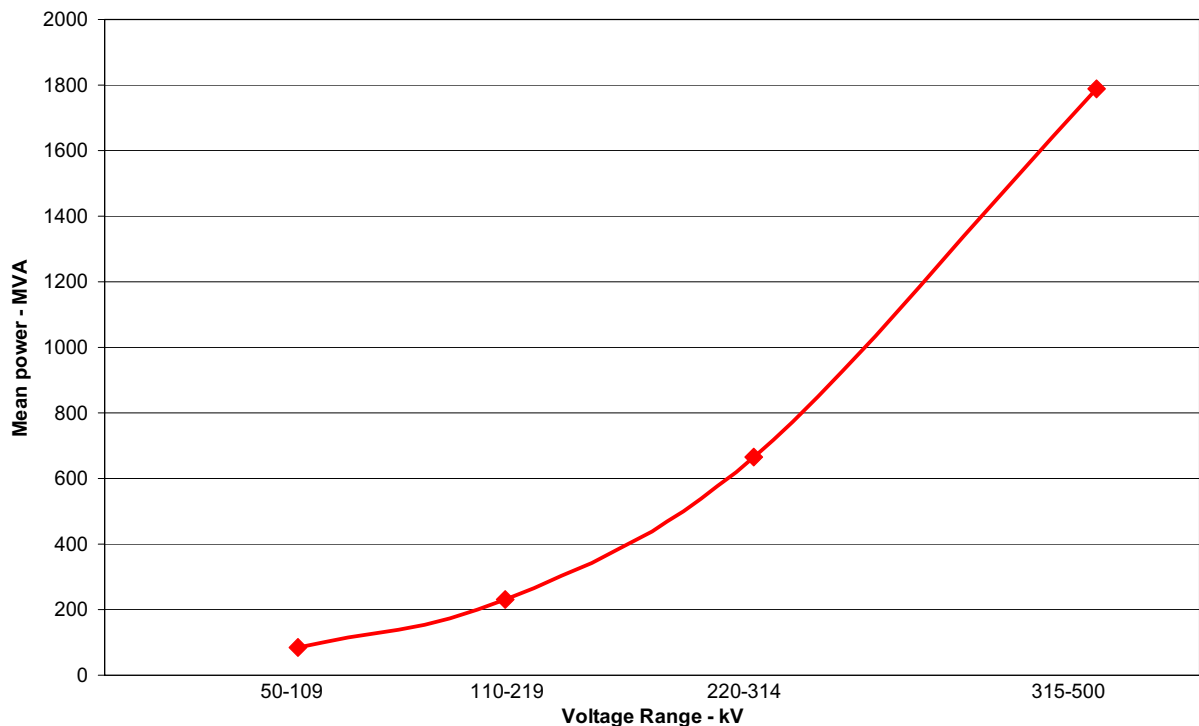

Figure 3.7: Average rating of circuits in the voltage ranges used in the questionnaire

### 3.3 Construction and Installation

#### Cables

Putting the cables underground is a significant part of the cost of a project. The cost varies widely depending on the ease of access along the route and the amount of power to be transmitted.

In urban areas, the costs of cable installation tend to be significantly higher than in the countryside. In the city, there are likely to be a large number of crossing services, for example gas, water, telecommunications (figure 3.8). This restricts the use of mechanical diggers and parts of the trench have to be dug by hand. The trench walls usually have to be supported in order to work safely (figure 3.9). Additional costs arise from the need to manage the traffic flow and from the restrictions often placed on the hours of working in order to reduce inconvenience to local residents.



Figure 3.8: 110 kV cable trench in an urban street



Figure 3.9: Trenches with shuttered (supported) walls

The length of time that a trench needs to remain open can be reduced by first installing ducts (often plastic or steel pipes). These can be buried in short sections and then the cable subsequently pulled in (figure 3.10). This is most effective for smaller, lighter cables with modest thermal ratings.

For minimum disruption, cables can be installed in deep bored tunnels. This is an expensive method, but in major cities it is sometimes the only practical option.



Figure 3.10: Cable being pulled through a pre-installed plastic duct

In rural or open areas, the costs of cable installation are likely to be reduced. A mechanical excavator can often be used to dig the trench and there may be sufficient space and suitable soil conditions to dig a trench with unsupported sloping walls (figure 3.11).

There may be significant additional costs with large-scale rural undergrounding in order to preserve the natural environment (for example watercourses, hedgerows and woodlands)

Special techniques such as directional drilling are also used for crossings under roads, railways and waterways. Further details on construction works and the installation of underground cable are given in Appendix D.



Figure 3.11: Cable trench on open land

The size and spacing of trenches is largely dictated by the rating of the cable. It was noted in Section 3.1 above that, as a general rule, the higher the voltage at which an electric circuit operates, the larger power it can transmit and the higher the losses. In consequence higher voltage cables tend to be spaced further apart and more attention has to be paid to the dissipation of heat.

Ease of installation and the electrical design of cable systems favours placing the three phase cables as close together as possible. Hence low and medium voltage cables tend to be buried in touching trefoil formation (see figure 3.12). For very high power transmission, the need for better heat dissipation means that the cables should

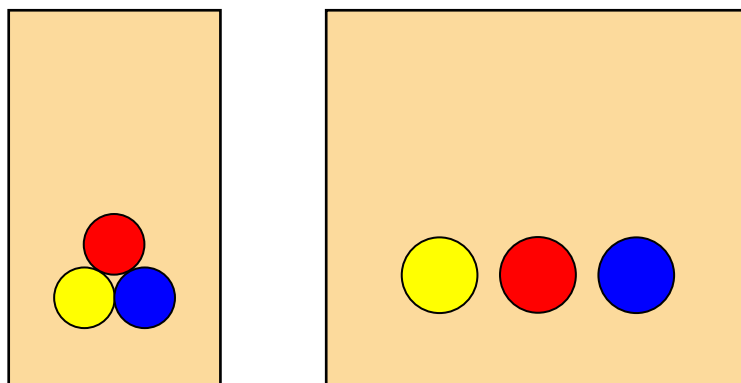

Figure 3.12: Cables installed in trefoil (left) and flat formation (right)

be spaced further apart, generally in flat formation. This represents a compromise between thermal and electrical requirements. Where two circuits are installed, for example to connect to a double circuit overhead line, the most efficient cooling is obtained by placing the two cable circuits as far apart as practically possible.

The spacing between overhead line conductors is so large that heat dissipation from each conductor is unaffected by the presence of the other current carrying conductors.

The trench cross-section and construction work on a high voltage (66-90 kV) cable are shown in Figure 3.13. The extent of the work is considerable less than that required to install a very high power extra-high voltage link. Figure 3.14 shows the trench cross-section for a 400 kV double circuit cable. The high rating (up to 4800 MVA) requires two cables per phase. Figure 3.15 shows construction work on such a link in the UK. In order to make the circuits thermally independent they are installed at a wide spacing. The gap between the the circuits is useful during construction as it allows a temporary access road to be laid between the circuits. This improves safety and minimises damage to the land. Taking care to reduce land compaction and carefully reinstating land drains plays an important role in promoting the future growth of crops.

To the left of the circuits the topsoil is stored. Storing topsoil on-site reduces the number of truck movements and helps ensure that the original topsoil is replaced after the cables are buried. The disadvantage is that a wider swath of land is required during construction. In addition to the space required for safe working and access requirements for the underground cables themselves, extra land may also be needed at the joint positions.

After construction it must still be possible to access the cable quickly if a repair is needed. In addition, buildings on top of the cable route are not permitted due to the need for good heat transfer.

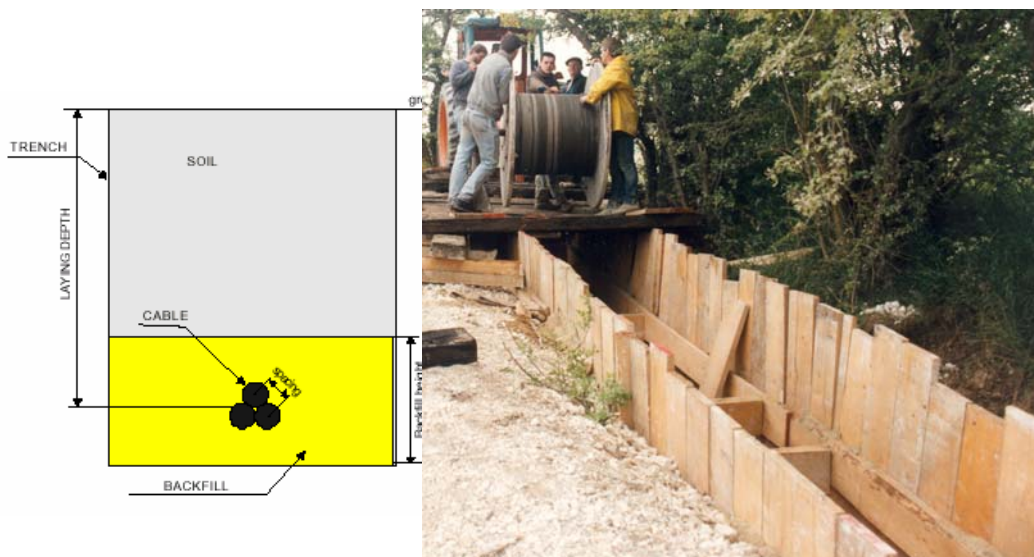

Figure 3.13 Trench cross-section and construction activity for a high voltage (66-90 kV) cable

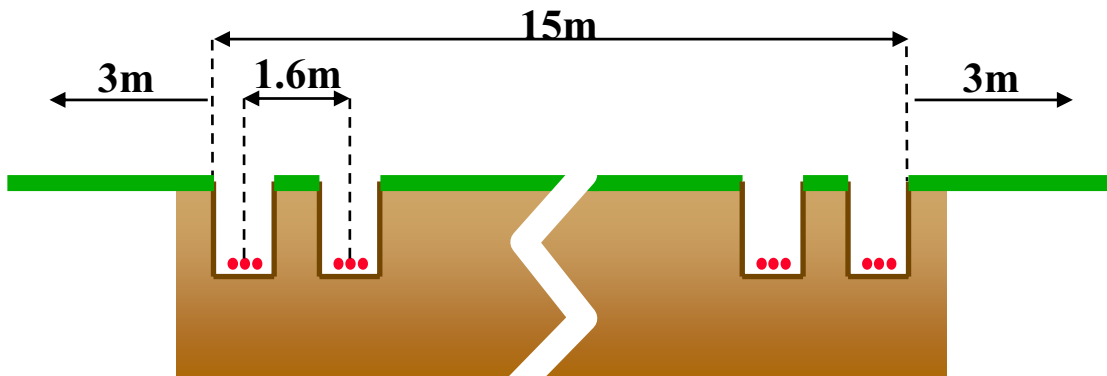

Figure 3.14 Trench cross-sections for an extra-high voltage (400 kV) cable system



Figure 3.15 Construction swath for the Nunthorpe-Newby 400 kV cables in the UK. Further details on this installation are given in Appendix G.

## **Joints**

The technology required to joint cables tends to become increasingly complex (and costly) with increasing voltage. The electric field (stress) in the insulation of a 60 kV cable is a few kV/mm. In order to reduce the size and weight of 400 kV XLPE cables, these operate at a much higher stress (about 12 kV/mm). The increased stress results in a cable that is more expensive to manufacture, requires a more sophisticated joint design and much greater care during installation. Details of the designs of joints used with underground cables can be found in CIGRE Technical Brochure 177 [3]

Joints are more complex than the cable itself and are made on-site rather than in the factory. In consequence the joints tend to be less reliable than the cable. The higher voltage cables tend to be heavier and less flexible than lower voltage cables. This leads to shorter drum lengths (delivery lengths) for the higher voltage cables and hence more joints per kilometre. To maintain reliability extreme care is required in the installation and testing of 400 and 500 kV cable joints.

After jointing, the cable is usually subjected to a high voltage test to prove the quality of the joint. At 400 and 500 kV the equipment required for this test is very large and special provisions are often required to get the test equipment to site.

For an overhead line only the conductor needs to be jointed and this is usually achieved with a simple compression fitting.

## **Transitions**

At the end of an underground cable a termination is applied to control the electric field. Factors influencing the design, installation and testing of terminations are very similar to those of joints (above).

When a section of underground cable is incorporated in an overhead transmission line, the connection from a fully insulated cable to a bare overhead conductor is by means of a termination, but how this is implemented depends on the voltage of the circuit.

At lower voltages the terminations can normally be located and supported within the overhead line tower structure (see figure 3.16)

At intermediate voltages (220/275 kV) the terminations can be mounted on the tower by installing a platform on the tower (figure 3.17).



Figure 3.16 Tower-mounted terminations on a 90 kV line





Figure 3.17 Terminations mounted on a platform on a 110 kV overhead line tower

At 400 and 500 kV, the size and weight of terminations and the necessary clearances dictate the use of a separate, high security transition compound on the ground (Figure 3.18). The compound can require an area of 2,500 m<sup>2</sup> depending on the power level and the amount of equipment installed. The overhead line tower at this location is more substantial because the line terminates at this point and hence the mechanical forces on the tower are unbalanced.

For further details on transitions between overhead and underground circuits see CIGRE Technical Brochure 250 [4].



Figure 3.18: 400 kV transition compound

### ***3.4 Electrical Design***

The above sections (3.1 to 3.3) show that not only are there major differences between the thermal and construction aspects of overhead and underground circuits, but there are also significant differences between low power high voltage underground cables and very high power extra-high voltage cables. A similar situation exists for the electrical design of these systems.

The electrical design of long AC cable links and their integration into overhead networks has already been considered in detail by CIGRE Working Groups 21-13 [5] and B1.19 [4,6] so it will only be considered very briefly here.

#### **Fault Clearance and Protection**

When a fault occurs in an overhead line circuit it is often a transient fault caused, for example, by a lightning strike. It is common practice to attempt to re-energise the circuit by automatically reclosing the circuit-breaker. This may be done immediately or after a delay of between 1 and 20 seconds (delayed auto reclose).

When a fault occurs in an underground cable circuit it is almost exclusively a permanent fault [7] and reclosure is not attempted.

The automatic reclosure of a hybrid overhead/underground circuit may be possible, but the attendant risks (injury, explosion and fire) have to be evaluated. Automatic reclosure is facilitated by fitting extra equipment to detect if the fault is in the overhead or underground part of the circuit. Reclosure can then be attempted if it is indicated that the fault is in the overhead part. (See Appendix C.1).

### **Special Bonding**

It was noted in Section 3.2 that current flowing in the cable conductors induces current in the metallic sheaths of the cables, which produces heat (sheath loss). If the cable sheath is solidly bonded to earth at both ends of the circuit large currents will flow in the sheath leading to high sheath losses. This will reduce the current rating of the cable. For highly rated cables special bonding techniques can be used to minimise the sheath losses. These arrangements are described in Appendix C.2.

### **Parallel Connections**

The impedance of an underground cable is usually lower than that of an overhead line. If the two are run in parallel, it is likely that most of the current will flow in the cable. This situation must be analysed at the design stage and measures to control the current flow have to be considered. (See Appendix C.3).

### **Reactive Compensation**

An underground cable acts as a capacitor. When subjected to alternating voltage, the cable is repeatedly charged and discharged. This charging (or reactive) current flows between the central conductor and the metal sheath, making no useful contribution to the flow of power along the cable.

For a 400 kV cable the charging current is 10-40 times greater than for an equivalent overhead line conductor. For long cable routes it is necessary to install reactive compensation equipment (usually inductance in the form of shunt reactors). This equipment and associated switchgear and connections add to the cost of long underground circuits. For practical reasons it is preferred to install shunt reactors at the substation or at the overhead/underground transition compound. Further details of reactive compensation are given in Appendix C.4.

### **3.5 Operation**

There are significant differences in the operational aspects of overhead and underground circuits and once again differences between low power high voltage underground cables and very high power extra-high voltage cables.

#### **Security of Supply**

The question of whether an overhead line or an underground cable provides a better security of supply is not a simple matter. Both systems are intrinsically very reliable if well designed, constructed and maintained. However, there is considerable variation in operation, environment and maintenance practices throughout the industry, making direct comparison difficult.

In temperate countries, an overhead line can provide a more secure electricity supply than an underground cable, as an overhead line is not subject to damage from digging activities by third parties, which may be considerable (often due to the non observance of the permits and laws).

However, in extreme weather conditions, this is not necessarily the case. Wind, snow and ice storms can cause extensive damage to overhead systems, while underground systems are immune from them. Damage from falling trees can also be a problem for overhead lines, particularly for lower voltages lines. This is less of a problem for very high voltage lines with their taller towers.

Where overhead lines cross areas of poor soil stability the foundations of towers must be strengthened accordingly. Similar approaches can be used with underground cable, for example installing the cable in piled troughs or reinforced concrete duct banks. The cost is correspondingly higher because the strengthening is required along the entire route rather than being restricted to the tower positions.

In earthquake zones, it might be thought that underground cables would be likely to suffer severe damage due to vibration and lateral spreading. In the past two decades there have been three major earthquakes in which damage to underground cables might have been expected. In California (USA) there were the Loma Prieta quake (1989), affecting the San Francisco Bay Area and the Northridge quake (1994) affecting the Los Angeles area. In neither case were transmission cables damaged.

In 1995 a major earthquake (the Hyogoken-Nanbu quake) severely affected the area around Kobe, Japan. One major cable fault occurred, when oil leaked from an oil-filled cable installed in a duct. In addition, there were two faults affecting minor installations (a gas-filled cable and a submarine cable were both severed). These cases suggest that investing in cable systems designed to withstand seismic forces can minimize the damage suffered. The cost depends on what kind of seismic phenomenon is expected (for example liquefaction or dislocation) and the inherent resistance of the cable system to

mechanical forces. In cases where an underground cable does suffer damage it is likely to require a longer outage for repair than the equivalent overhead line.

### **Fault Repairs**

In the case of an overhead line, a fault can be quickly found by visual means using either a manual line patrol or, in urgent cases, by helicopter patrol. Repair to overhead lines is relatively simple in most cases and the line can usually be put back into service within a few days. However, major catastrophic failures do occur involving multiple circuits and can take many months to repair. In some cases the use of temporary support structures allows rapid restoration of the overhead circuit.

Underground cable failures tend to affect only a single circuit. An underground cable fault can be difficult to locate by electrical means, if obvious excavation damage is not present, and typically takes one to several weeks to repair.

### **Routine Maintenance**

The annual maintenance costs and outage times required vary considerably from country to country, as utilities have different maintenance practices.

For instance, some countries annually test all cable sheaths to confirm their integrity; other countries do not. Such testing is costly in outage terms, but can pay dividends in the long run. In addition, the additional complexity of fluid-filled cable systems requires more intensive routine and corrective maintenance than extruded dielectric systems.

On the other hand, much of the annual inspection work on overhead lines can be performed with the lines in service, by ground-based observers or from helicopter patrols. The major cost is incurred when corrective maintenance identified by these patrols is carried out. In addition, climbing patrols are also carried out (typically every 5 years or so) to check out in detail the condition of all the hardware on the towers. To prevent corrosion, it is common practice to paint the towers at regular intervals.

### **Safety**

Overhead lines are highly visible structures and are rarely damaged unintentionally by third parties. However, if people get too close to high voltage overhead conductors fatalities can occur. Falling conductors and masts also are a danger in extreme conditions.

As underground cables are not readily visible, it is not uncommon for these to be damaged by excavators, drilling operations and suchlike. This can cause major damage and injury. The incidence of such events is rather low, as cable protection systems operate extremely quickly, and the underground locations tend to limit the spread of fire and hazardous materials. In most countries, contractors are encouraged to contact the

relevant utilities before commencement of excavations; this is mandatory in certain countries.

## **Up-rating**

Up-rating is a way to transfer more power over an existing overhead line or cable system. This can be done with or without hardware changes.

Changing the hardware of an overhead line is generally much easier than an underground cable. (See Appendix E.1 for further details).

Up-rating a circuit by using temperature monitoring and real time thermal rating is useful for short term operations. This is particularly effective for underground cables. The time taken for a cable and the surrounding soil to heat up is significant. It is therefore often possible to pass additional current down a cable for some hours without the cable overheating. The time constant for heating an overhead line is much shorter, generally minutes rather than hours.

Further details on the short-term ratings are given in Appendix B.

## **Monitoring**

Details of systems for monitoring the health and temperature of underground cable are given in Appendix E.2. Routine monitoring of overhead lines has rarely been used in the past, but with increasing pressure to maximise the power flows down existing lines, such systems are being evaluated and introduced.

For the safe operation of oil-filled and gas pressure cables it is necessary to monitor oil or gas pressure. This may be done using simple pressure gauges fitted with low pressure alarm contacts or, for more recent installations, using pressure transducers.

For modern XLPE cable systems partial discharge (PD) monitoring is being introduced, particularly for joints and terminations. The sensors are relatively simple but the detection and evaluation of the signals is very complex. Monitoring PD in XLPE cable systems can improve their reliability by giving early warning of degradation.

Temperature measurements can be obtained simply from discrete sensors such as thermocouples, which can be placed in the ground and on the cable sheath at specific points.

More comprehensive measurements can be done using a distributed temperature sensing (DTS) system where an optical fibre cable is used to continuously monitor the temperature profile along the cable route. Temperature measurements can be used with real-time rating software to give enhanced short-term ratings for underground cable.

### ***3.6 Reducing the cost of undergrounding***

In addition to using monitoring to increase the cost effectiveness of cable assets, utilities are using a range of other techniques to reduce the cost differential between underground cables and overhead lines.

Improvements in cable design are leading to lighter cable and hence longer drum lengths. The most significant changes are the use of laminated foil sheaths rather than the thicker seamless metallic sheaths. The use of higher electrical stresses reduces the thickness of cable insulation. In addition to using less material this reduces the number of joints, leading to reduced cost and shorter installation times.

The cost of installation can also be reduced by the use of mechanised laying techniques. The cable trench can be excavated, the cable laid and the trench backfilled in a single pass. Figure 3.19 shows the mechanised laying of a 20 kV cable bundle. For larger cables mechanised laying techniques can be used to bury plastic ducts [8]. The cables can subsequently be pulled into the ducts. Figure 3.20 shows the mechanised laying of 63 kV cable ducts. A novel method for pulling the cables has been trialled [9]. As the cable is winched, water is pumped through the duct providing both buoyancy to the cable and forward momentum to assist the cable pulling. The use of pre-lubricated ducts can also reduce friction and hence the pulling force required.

Mechanised laying techniques are mainly applicable to light, low power cables in rural environments. They are less useful if there are other (crossing) underground services or if the use of a special backfill is required to assist heat dissipation from the cable. There is also a practical limit to the weight of cable that can be laid and laying may not be possible during wet seasons.



Figure 3.19: Mechanised laying of a 20 kV cable bundle



Figure 3.20: Mechanised laying of 63 kV cable ducts



## **Deferring Expenditure**

There may be circumstances in which a cable has to be connected to an overhead line whose rating is far greater than the present day need. It may be economic to install a cable that meets the present day requirements and then install a second cable per phase once the load has grown sufficiently [10]. For a ducted cable system it may be more economic to install spare ducts during civil work for the initial installation

For a cable installed in a tunnel provision can be made for future network expansion by leaving space in the tunnel for additional circuits.

Where it is anticipated that forced cooling will be needed to meet the future rating, it may be possible to defer expenditure by not installing the full cooling system until a later date. For a water-cooled cable, water pipes could be installed without the water cooling stations and heat exchangers or refrigeration. Similarly, where a high pressure oil-filled (pipe type) cable system is installed the cooling system (oil radiators and fans) could be added later.

Temperature measurement and real-time rating techniques also provide an option for deferring expenditure by extending the time for which the existing cable meets the need.

## **Tailored Solutions**

Overhead lines provide an off-the-shelf solution to the provision of transmission circuits. They generally utilise a standardised range of designs for conductor, insulators strings and towers. The relatively low cost of overhead transmission means that there is little benefit from applying novel or bespoke solutions to each line. The converse is true for underground transmission. It is relatively expensive and hence despite the additional cost of one-off designs, it is still possible to make significant savings from tailored solutions. This is particularly true of novel installation designs and techniques.

One consequence of this approach is that an underground cable system can be tailored to meet local conditions, but the same solution may not be applicable elsewhere. Hence, even for the same voltage and power, the costs of an underground cable system can vary widely. This makes it difficult to generalise the cost of a typical underground cable system or even to get a consensus on what a typical underground cable system looks like. Each installation must be taken individually and the relevant costs calculated.

## **4 Cost Factors**

The statistics of installed lengths reported in Chapter 2 show that utilities generally prefer to use overhead lines rather than underground cables. This is primarily on the grounds of cost, although as shown in Chapter 3, there are also a number of technical factors which favour overhead lines.

Before considering in detail the components which go to make up the cost of an underground cable circuit, we shall first consider how best to compare the cost of underground cables with the equivalent overhead line.

#### 4.1 Cost Ratios

Cost ratios are often thought of as simple way of comparing costs, for example saying an underground cable is 10 times as expensive as overhead line. In reality there can be a wide range of values quoted for apparently similar circuits and this leads to confusion and mistrust between the various stakeholders.

Cost ratios are volatile, in particular, they are highly sensitive to small changes in overhead line cost and as a result they must be used with extreme caution. Table 4.1 shows some hypothetical cost ratios for underground to overhead costs. In both cases the underground cable costs €10 million (€10M). In Case 1 the overhead line costs €500 thousand (€500k). In the second case, small changes in the overhead line design or the local ground conditions result in the overhead line costing €1M. The cost ratio for Case 1 is 20, whilst for Case 2 it is 10. The important factor is the additional cost of placing the link underground, which is similar in both cases (€9.5M in Case 1 against €9.0M in Case 2.)

Table 4.1: Hypothetical cost ratios for underground to overhead costs

Case	Cost of underground cable	Cost of overhead line	Cost ratio	Additional cost of undergrounding
1	€10 million	€500 thousand	20	€9.5 million
2	€10 million	€1 million	10	€9.0 million

Small changes in the design of the circuit can produce large changes in cost ratios and, in financial terms, the ratios have little meaning. It is the added cost of undergrounding that is important and must be weighed against the benefits (largely visual) that it brings.

In their 1996 study [1,2], CIGRE Joint Working Group 21/22-01 tried to gather international values for cost ratios, but as might be expected the results were of limited use. For circuits operating at voltages between 220 kV and 362 kV, JWG 21/22-01 found cost ratios ranging between 5 and 21.

The quoted ratios vary widely, because they are highly dependent on local circumstances (including terrain, land costs and power flows).

The present Working Group considered the option of collecting international costs for a well-defined ‘typical’ cable circuit, but it is even difficult to obtain international consensus on what might constitute a ‘typical’ cable circuit.

The Working Group has concluded that it is not possible to collect a consistent set of data for overhead and underground costs that would give more reliable cost ratios than those obtained in 1996.

The only reliable method of comparing overhead and underground costs is on a case by case basis. Generic values of cost ratio are of very limited use and should be avoided. Estimates for the costs of underground and overhead options for a specific project must be calculated and then weighed against the advantages and disadvantages of each option.

## ***4.2 Components of cost for cable systems***

Costs can be estimated for the various stages of the cable's lifecycle:

- Planning/Design
- Procurement
- Construction
- Operation
- End of Life

Each stage of life can be subdivided further and the costs estimated. See Appendix F for further details.

In general the early capital costs, particularly procurement and construction, are usually found to be the most significant. They are immediate and tend to be larger than later costs such as repair and maintenance and hence have most effect on the financing of projects.

Later costs can be very difficult to estimate. It is particularly difficult to estimate both the magnitude and the cost of future electrical losses. The magnitude of losses are highly dependent on how heavily the line will be loaded and the cost of the losses depends on factors such as the cost of fuel and the availability of surplus generation capacity. None of these factors are easy to estimate even in the short-term. Estimating their likely values in 40 years' time is extremely difficult, particularly in a deregulated environment.

By analysing the underground cable costs for each stage of the cable's life, it is easier to assess which costs are important and which estimates are least reliable. A similar methodology can be used to estimate the cost of the equivalent overhead line.

## ***4.3 Comparing underground and overhead options***

The only reliable way of comparing the costs of underground and overhead options is on a case by case basis. There is no general answer to how the costs compare. In Chapter 3,

technical options for reducing the cost of undergrounding were discussed. These often involve a willingness to be flexible in the design of installations rather than just accepting a standard design solution. This in itself makes the concept of a standard cost for a circuit untenable.

Historic values of underground and overhead costs are often a poor guide to present day costs. The price of underground cable is strongly influenced by fluctuations in the commodity price of raw materials such as copper. It is also expensive to manufacture and store large stocks of cable, particularly for the very high voltages. In consequence the price of underground cable is very sensitive to the balance between demand and manufacturing capacity.

The other problem with using historic values of underground and overhead costs is that underground cable has traditionally been used mainly in the centres of towns and cities with overhead lines being used for rural transmission circuits. There has therefore been a tendency to compare the cost of urban underground cable with that of rural overhead line, which may give an inaccurate comparison.

For each individual project, the costs of underground and overhead options must be calculated and these can then be compared. Once the cost difference has been calculated, this can be compared with those benefits and threats which are more difficult to express in monetary terms. These include factors such as visual intrusion, threats to sensitive habitat and damage to archaeological heritage.

There are also land-use issues which need to be considered, where the installation of an overhead line or underground cable might restrict future options for either agriculture or suburban building development.

Factors such as visual intrusion and threats to sensitive habitat are not generally the same along the whole route. In some cases partial undergrounding is an opportunity for compromise. As shown in Chapter 3, however, the transition from overhead to underground can have significant impact on the local environment and adjacent short sections of undergrounding are unlikely to be desirable.

However even that generalisation may be unwise without considering the details of a specific case. Only by calculating the cost differential between underground and overhead options for a particular circuit can this be weighed against the other benefits and threats to give a rational basis for a decision.

## 5 Conclusions

The large majority of circuits are overhead. The proportion of ac circuits that are underground falls from 6.6% for the 50 to 109 kV range down to 0.5% for the 315 to 500 kV range. There is no significant length of underground transmission at the 501 to 764 kV level.

The percentage of underground cable which has extruded polymeric insulation falls from 72% for the 50 kV - 109 kV range to 27% for 315 - 500 kV range. The decreasing proportion of extruded insulation used at the higher voltages reflects the relatively recent introduction of this technology.

The data on installed lengths clearly show that utilities have a strong preference for overhead lines rather than underground cables. For the 50 kV to 109 kV range, 93% of the ac network is overhead. This value increases to 100% overhead at the 501-764 kV level.

The preference for overhead lines is mainly on the grounds of cost and some technical issues. The cost driver becomes stronger as the voltage level increases. The main technical differences between the underground and overhead transmission of bulk electric power relate to electrical insulation of the conductor, heat transfer to prevent overheating and the construction work necessary to install the circuit. These combine and result in the additional cost and complexity of placing circuits underground. This situation becomes worse at higher power and voltages.

There are also significant differences in electrical design and system operation between underground cables and overhead lines.

Cost ratios are often thought of as simple way of comparing costs, but there can be a wide range of values quoted for apparently similar circuits and this leads to confusion and mistrust between the various stakeholders.

Cost ratios are volatile; in particular, they are highly sensitive to small changes in overhead line cost and as a result they must be used with extreme caution. Small changes in the design of a circuit can produce large changes in cost ratios and, in financial terms, the ratios have little meaning. It is the added cost of undergrounding that is important and must be weighed against the benefits (largely visual) that it brings.

In the 1996 study cost ratios ranging between 5 and 21 were quoted for circuits operating at voltages between 220 kV and 362 kV. The quoted ratios vary widely, because they are highly dependent on local circumstances (including terrain, land costs and power flows).

The present Working Group concluded that it is not possible to collect a consistent set of data for overhead and underground costs that would give more reliable cost ratios than those obtained in 1996.

The only reliable method of comparing overhead and underground costs is on a case by case basis and generic values of cost ratio are of very limited use and should be avoided. Estimates for the costs of underground and overhead options for a specific project must be calculated and then weighed against the advantages and disadvantages of each option.

Technical options for reducing the cost of undergrounding have been considered. These often involve a willingness to be flexible in the design of installations rather than just accepting a standard design solution. This in itself makes the concept of a standard cost for a circuit untenable.

Historic values of underground and overhead costs are often a poor guide to present day costs. Underground cable has traditionally been used mainly in the centres of towns and cities with overhead lines being used for rural transmission circuits. There has therefore been a tendency to compare the cost of urban underground cable with that of rural overhead line, which may give an inaccurate comparison.

For each project, the costs of underground and overhead options must be calculated and these can then be compared. Once the cost difference has been calculated, this can be compared with those benefits and threats which are more difficult to express in monetary terms. These include factors such as visual intrusion, threats to sensitive habitat and damage to archaeological heritage.

There are also land-use issues which need to be considered, where the installation of an overhead line or underground cable might restrict future options for either agriculture or suburban building development.

Factors such as visual intrusion, threats to sensitive habitat, etc. are not generally the same along the whole route. In some cases partial undergrounding is an opportunity for compromise, but the transition from overhead to underground can have significant impact on the local environment and adjacent short sections of undergrounding are unlikely to be desirable.

Underground cable systems can be tailored to meet local conditions, but the same solution may not be applicable elsewhere. Hence, even for the same voltage and power, the costs of an underground cable system can vary widely. This makes it difficult to generalise the cost of a typical underground cable system.

Only by calculating the cost differential between underground and overhead options for a particular circuit can this be weighed against the other benefits and threats giving a rational basis for a choice between overhead and underground transmission.

## 6 References

1. Comparison of overhead lines and underground cables, CIGRE Technical Brochure 110, December 1996
2. Comparison of overhead lines and underground cables for electricity transmission, CIGRE Session Paper 21/22-01, Paris, 1996
3. Accessories for HV Cables with Extruded Insulation, CIGRE Technical Brochure 177, February 2001
4. General guidelines for the integration of a new underground cable system in the Network, CIGRE Technical Brochure 250, August 2004.
5. Operating characteristics of long links of AC high voltage insulated cables, CIGRE Session Paper 21-13, Paris, 1986
6. Technical issues regarding the integration of HVAC underground cable systems in the Network, CIGRE Session Paper 21-108, Paris, 2002.
7. Reliable fault clearance and back-up protection, CIGRE Technical Brochure 140, April 1999
8. Marty L. and Le Corguille J.L., Mechanical laying of HDPE ducts in rural area, Jicable Conference 2003, Paris, Paper A.10.2, pp333-337
9. Trichard C., et al., Innovative installation method using water as a carrying fluid to install power cables in-pre-lubricated ducts in trenches of reduced dimensions, Jicable Conference 2003, Paris, Paper A.10.5, pp349-352
10. Goultly GA, Visual Aspects of High Voltage Transmission, John Wiley & Sons, 1989, p166
11. Thermal behaviour of overhead conductors, CIGRE Technical Brochure 207, August 2002.
12. Guide for selection of weather parameters for bare overhead conductor ratings, CIGRE Technical Brochure 299, August 2006
13. The design of specially bonded systems, Electra 28, 1973
14. The design of specially bonded cable circuits, Part II, Electra 47, 1976

15. Guide to the protection of specially bonded cable systems against sheath overvoltages, Electra 128, 1990, pp46-62
16. Special bonding of high voltage power cables, CIGRE Technical Brochure 283, October 2005
17. Construction, laying and installation techniques for extruded and self contained fluid filled cable systems, CIGRE Technical Brochure 190, August 2001.
18. High voltage overhead line environmental concerns, procedures, impacts and mitigations, CIGRE Technical Brochure 147, October 1999
19. Life cycle assessment (LCA) for overhead lines, CIGRE Technical Brochure 265, December 2004
20. Environmental management plans for activities associated with overhead lines, CIGRE Electra 212, February 2004, p57
21. Consultation models for overhead line projects, CIGRE Technical Brochure 274, June 2005
22. Upgrading and uprating of existing cable systems, Working Group B1.11, CIGRE Technical Brochure, to be published.
23. Magnetic field in HV cable systems: 1 - systems without ferromagnetic component, CIGRE Technical Brochure 104, June 1996.
24. Magnetic field calculation in underground cable systems with ferromagnetic component, Electra 174, October 1997, pp78-89
25. How OH lines are re-designed for uprating/upgrading. Analysis of the answers to the questionnaire, CIGRE Technical Brochure 294, June 2006
26. Guidelines for increased utilization existing overhead lines, Working Group B2.13, CIGRE Technical Brochure, to be published.
27. Optimization of power transmission capability of underground cable systems using thermal monitoring, CIGRE Technical Brochure 247, April 2004
28. The influence of line configuration on environment impacts of electrical origin, CIGRE Electra 221, August 2005, p53
29. The influence of line configuration on environment impacts of electrical origin, CIGRE Technical Brochure 278, August 2005



## Appendix A     STATISTICS OF INSTALLED LENGTHS

### *A.1 Collection of Data*

The 1996 report from the Joint Working Group 21/22 examined the worldwide usage of high voltage overhead transmission lines and underground cables [1,2]. It also examined a number of regulatory, technical and environmental issues. As a consequence, the questionnaire was 22 pages long and some of the data collected were difficult to interpret. Our working group reviewed the information obtained by JWG 21/22 and considered the resources necessary to gather that data from utilities in current circumstances. It was decided to concentrate our effort on updating the statistics of installed lengths. We were aware of the considerable time and effort that is needed to fill in a long questionnaire. The information that we requested was the minimum needed to complete our update.

We prepared a short questionnaire dealing only with the lengths of circuits that are currently installed. The Excel spreadsheet used to gather this information is shown in Figure A.1.

The data requested were lengths of underground and overhead circuits in five voltage ranges.

- 50-109 kV
- 110-219 kV
- 220-314 kV
- 315-500 kV
- 501-764 kV

The voltages referred to are the nominal phase-to-phase system voltage. The voltage ranges were chosen to group together similar design and operational principles as far as possible.

The data following guidance was offered to respondents:

#### **Rating Range (MVA)**

The complexity (and cost) of transmission circuits is significantly higher for large power flows. We would like some information on the typical design circuit ratings for your system at each voltage level. For simplicity we are asking for the ratings (transmission capacity) of OHL only.

This is obviously difficult as you may have many different types of conductor and installation at each voltage, but please give the continuous rating or range of continuous ratings for typical OHL at each voltage. If there are significant differences between cable and OHL ratings on your system please indicate this.

## **OHL**

This is the total number of circuit km of ac OHL installed on your system. This includes circuits that were in use when the 1996 survey was carried out. Please include any lines that are approved or under construction and will be completed by December 2006.

The circuit km reported should be the lengths of circuit installed, ignoring the number of subconductors used for each phase. So a 5 km long double-circuit line with three conductors per phase should be reported as 10 circuit km.

## **Cable - Extruded and Lapped**

We are only interested in AC land cables. Since we are collecting data on transmission circuit lengths please do not include short lengths of cable installed across substations, power stations, etc.

We would like an indication of the insulation used. To keep this simple, we have restricted the insulation to only two types: extruded (XLPE, LDPE, EPR, etc) and lapped paper (oil-filled, pipe-type, mass impregnated, etc)

To simplify the collection of data, in the category 50-109kV, no distinction will be made between extruded cables and lapped cables (unless data is readily available)

The circuit km reported should be the lengths of circuit installed, ignoring the number of cables used for each phase. So a 5 km long double-circuit connection with 3 phases and two cables per phase should be reported as 10 circuit km even though it has 60 km of cable core.

As with the lengths of OHL, we need the total length currently installed, so this includes the cables reported in 1996. Please include any circuits that are approved or under construction and will be completed by December 2006.

Figure A.1: Format of the questionnaire sent to members of CIGRE Study Committee B1

Country:				
Utility name or geographical area reported:				
Contact name				
Contact's email address				
Voltage Range	Rating range	OHL	Cable	Cable
	(MVA)	(Circuit km)	Extruded (Circuit km)	Lapped (Circuit km)
50 - 109				
110 - 219				
220 - 314				
315 - 500				
501 - 764				

## *A.2 Data received*

Responses were received from utilities in 28 countries. The majority of respondents were able to divide their cable data by insulation type. The proportion of cable for which it was possible to separate extruded cables and lapped cables varied from 89% for the 50 to 109 kV range up to 100% for the 315-500 kV range.

The responses were sorted by country and the data checked for any obvious typographical errors or misunderstandings. The data were then checked against alternative sources of data where available. These included utility web sites, company's annual reports, regulatory information, etc. The results were also compared with those from the 1996 study, although this is not a straightforward task and is considered further in section A.3.

Table A.1 is a summary of the basic data received. It shows the installed lengths of underground cable and overhead line at the voltage levels. No underground cable was recorded at the 501-764 kV level.

Table A.2 shows the installed lengths of underground cable and overhead line and the percentage of total circuit length which is underground at the 50-109 kV level

The equivalent data for the voltage ranges 110-219 kV, 220-314 kV, 315-500 kV and 501-764 kV are shown in Table A.3 to A.6 respectively.

Data on percentages of networks underground presented in the main body of the report (Figure 2.2 to 2.5) are for each country in decreasing order. Figure A.2 compares the results from Western Europe, Asia/Pacific and the Americas in the voltage range 110 kV to 219 kV.

Table A.1: Installed lengths of ac underground cable and overhead line at the voltage levels up to 500 kV.

	50-109 kV		110-219 kV		220-314 kV		315-500 kV	
	Cable (km)	OHL (km)	Cable (km)	OHL (km)	Cable (km)	OHL (km)	Cable (km)	OHL (km)
Australia	95	2153	201	13188	15	7151	58	6734
Austria			757	10282	5	3759	54	2453
Belgium	262	3007	311	3780	0	388	0	1481
Brazil	6	2735	0	9103	22	1405	55	6799
Canada	65	6849	398	24342	153	19786	16	12847
China			748	2017	156	1658	0	985
Croatia			53	4861	0	1248	0	1208
Denmark	1930	6000	515	3650	0	55	52	1300
Finland			280	15300	0	2400	0	4000
France	2316	48835	1	1064	903	25416	2	21007
Germany	857	13156	4972	76630	45	26790	65	18200
Ireland			171	4643	106	1723	0	438
Israel			100	4400			0	300
Italy	0	40	907	38278	197	10924	34	10651
Japan	11760	67989	1769	34732	1440	20594	123	15879
Korea	2	993	2144	16813	0	0	221	7563
Mexico	129	3450	595	44323	170	26500	3	19000
Netherlands	2558	289	1068	5495	6	677	7	1997
New Zealand	9	1339	127	6098	0	8376		
Poland			74	32227	0	8119	0	4830
Portugal	433	8253	2	2431	20	3080	0	1507
Romania			283	25909	8	5550	0	4389
Singapore	1185	0			651	0	111	0
Spain	509	10697	181	12220	479	18757	80	18806
Sweden	113	4265	334	14356	27	4417	8	10620
Switzerland	255	1634	547	1615	14	1539	0	1304
United Kingdom	1457	3073	2967	23192	496	6321	166	11122
USA	946	165830	2904	315309	663	116890	536	122176
Total	24886	350587	22408	746257	5575	323522	1589	307596

Table A.2: Installed lengths of ac underground cable and overhead line and the percentage of total circuit length which is underground at 50-109 kV

	Cable (km)	OHL (km)	Total (km)	% Cable
Australia	95	2153	2248	4.2
Belgium	262	3007	3269	8.0
Brazil	6	2735	2740	0.2
Canada	65	6849	6914	0.9
Denmark	1930	6000	7930	24.3
France	2316	48835	51151	4.5
Germany	857	13156	14013	6.1
Italy	0	40	40	0.0
Japan	11760	67989	79749	14.7
Korea	2	993	995	0.2
Mexico	129	3450	3579	3.6
Netherlands	2558	289	2846	89.9
New Zealand	9	1339	1348	0.7
Portugal	433	8253	8686	5.0
Singapore	1185	0	1185	100.0
Spain	509	10697	11206	4.5
Sweden	113	4265	4378	2.6
Switzerland	255	1634	1890	13.5
United Kingdom	1457	3073	4530	32.2
USA	946	165830	166776	0.6
Total	24886	350587	375473	6.6

Table A.3: Installed lengths of ac underground cable and overhead line and the percentage of total circuit length which is underground at 110 - 219 kV

	Cable (km)	OHL (km)	Total (km)	% Cable
Australia	201	13188	13389	1.5
Austria	757	10282	11039	6.9
Belgium	311	3780	4091	7.6
Brazil	0	9103	9103	0.0
Canada	398	24342	24740	1.6
China	748	2017	2765	27.0
Croatia	53	4861	4914	1.1
Denmark	515	3650	4165	12.4
Finland	280	15300	15580	1.8
France	1	1064	1065	0.1
Germany	4972	76630	81602	6.1
Ireland	171	4643	4814	3.6
Israel	100	4400	4500	2.2
Italy	907	38278	39185	2.3
Japan	1769	34732	36501	4.8
Korea	2144	16813	18957	11.3
Mexico	595	44323	44918	1.3
Netherlands	1068	5495	6563	16.3
New Zealand	127	6098	6225	2.0
Poland	74	32227	32301	0.2
Portugal	2	2431	2433	0.1
Romania	283	25909	26192	1.1
Spain	181	12220	12401	1.5
Sweden	334	14356	14690	2.3
Switzerland	547	1615	2162	25.3
United Kingdom	2967	23192	26159	11.3
USA	2904	315309	318212	0.9
Total	22408	746257	768665	2.9

Table A.4: Installed lengths of ac underground cable and overhead line and the percentage of total circuit length which is underground at 220 - 314 kV

	Cable (km)	OHL (km)	Total (km)	% Cable
Australia	15	7151	7166	0.2
Austria	5	3759	3764	0.1
Belgium	0	388	388	0.0
Brazil	22	1405	1427	1.5
Canada	153	19786	19939	0.8
China	156	1658	1814	8.6
Croatia	0	1248	1248	0.0
Denmark	0	55	55	0.0
Finland	0	2400	2400	0.0
France	903	25416	26319	3.4
Germany	45	26790	26835	0.2
Ireland	106	1723	1829	5.8
Italy	197	10924	11121	1.8
Japan	1440	20594	22034	6.5
Mexico	170	26500	26670	0.6
Netherlands	6	677	683	0.9
New Zealand	0	8376	8376	0.0
Poland	0	8119	8119	0.0
Portugal	20	3080	3100	0.6
Romania	8	5550	5558	0.1
Singapore	651	0	651	100.0
Spain	479	18757	19235	2.5
Sweden	27	4417	4444	0.6
Switzerland	14	1539	1553	0.9
United Kingdom	496	6321	6817	7.3
USA	663	116890	117552	0.6
Total	5575	323522	329097	1.7

Table A.5: Installed lengths of ac underground cable and overhead line and the percentage of total circuit length which is underground at 315 - 500 kV

	Cable (km)	OHL (km)	Total (km)	% Cable
Australia	58	6734	6792	0.9
Austria	54	2453	2507	2.2
Belgium	0	1481	1481	0.0
Brazil	55	6799	6854	0.8
Canada	16	12847	12863	0.1
China	0	985	985	0.0
Croatia	0	1208	1208	0.0
Denmark	52	1300	1352	3.8
Finland	0	4000	4000	0.0
France	2	21007	21009	0.0
Germany	65	18200	18265	0.4
Ireland	0	438	438	0.0
Israel	0	300	300	0.0
Italy	34	10651	10685	0.3
Japan	123	15879	16002	0.8
Korea	221	7563	7784	2.8
Mexico	3	19000	19003	0.0
Netherlands	7	1997	2004	0.3
Poland	0	4830	4830	0.0
Portugal	0	1507	1507	0.0
Romania	0	4389	4389	0.0
Singapore	111	0	111	100.0
Spain	80	18806	18886	0.4
Sweden	8	10620	10628	0.1
Switzerland	0	1304	1304	0.0
United Kingdom	166	11122	11288	1.5
USA	536	122176	122712	0.4
Total	1589	306287	307876	0.5



Table A.6: Installed lengths of ac underground cable and overhead line and the percentage of total circuit length which is underground at 501 - 764 kV

	Cable (km)	OHL (km)	Total (km)	% Cable
Canada	0	11422	11422	0.0
Korea	0	662	662	0.0
Poland	0	114	114	0.0
Romania	0	86	86	0.0
USA	0	4406	4406	0.0
<b>Total</b>	<b>0</b>	<b>16690</b>	<b>16690</b>	<b>0.0</b>

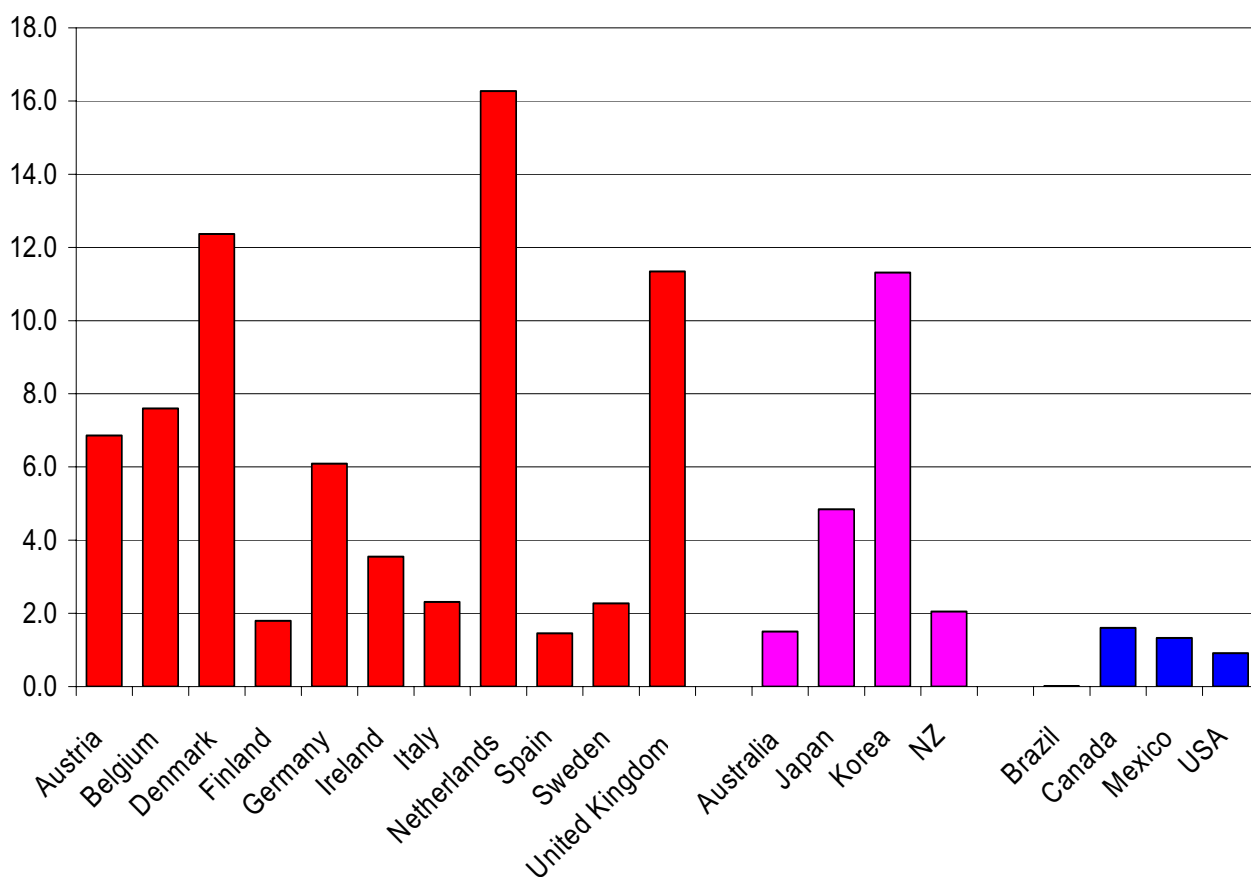

Figure A.2: Percentage of the total ac circuit length which is underground in the voltage range 110 kV to 219 kV; Comparison of results from Western Europe, Asia/Pacific and the Americas

### ***A.3 Comparison with the 1996 study***

Data for the 1996 study were collected in three voltage ranges:

- 110-219 kV
- 220-362 kV
- 363-764 kV

The main differences with our ranges are:

- In 1996, no data were collected for the 50-109 kV range
- The second and third ranges are split at 362 kV. This means that 345 kV and 400 kV networks are sorted into different ranges, even though they use similar design and operational principles.
- The upper level includes voltages above 500 kV where there is no significant use of underground cable.

Although the 1996 and 2006 studies use different voltage ranges, it is still possible to compare the cable data by combining results as follows:

1996	2006
110-219 kV	110-219 kV
220-362 kV and 363-764 kV*	220-314 kV and 315-500 kV

\* Note that there are no underground transmission cables at voltages above 500 kV.

Using this method it was possible to look for errors in our data, but this must be applied with great caution. The two data sets are not directly comparable. We obtained responses from utilities in 28 countries. (For details of the geographical coverage of the 2006 study see Table A.1). The 1996 study collected data from 18 countries. Not all countries in the 1996 study were able to respond to the 2006 questionnaire. In countries with a large number of utilities, those that responded in 2006 are not necessarily the same utilities that responded in 1996. Indeed, given the scale of deregulation and structural change over the last 10 years, many of the utilities that existed in 1996 no longer exist in the same form. Hence extreme caution must be used when comparing the 1996 and 2006 results. Any inconsistencies between the data sets are less of a problem when comparing overhead line data, where many thousands of kilometres of circuit are involved, but differences can appear large when comparing the much smaller lengths of underground cable.

Table A.7 and Figure A.3 compare the 1996 and 2006 data for lengths of underground cable in the range 220 kV to 500 kV. Table A.8 compares the 1996 and 2006 data for lengths of underground cable in the range 110 kV to 219 kV.

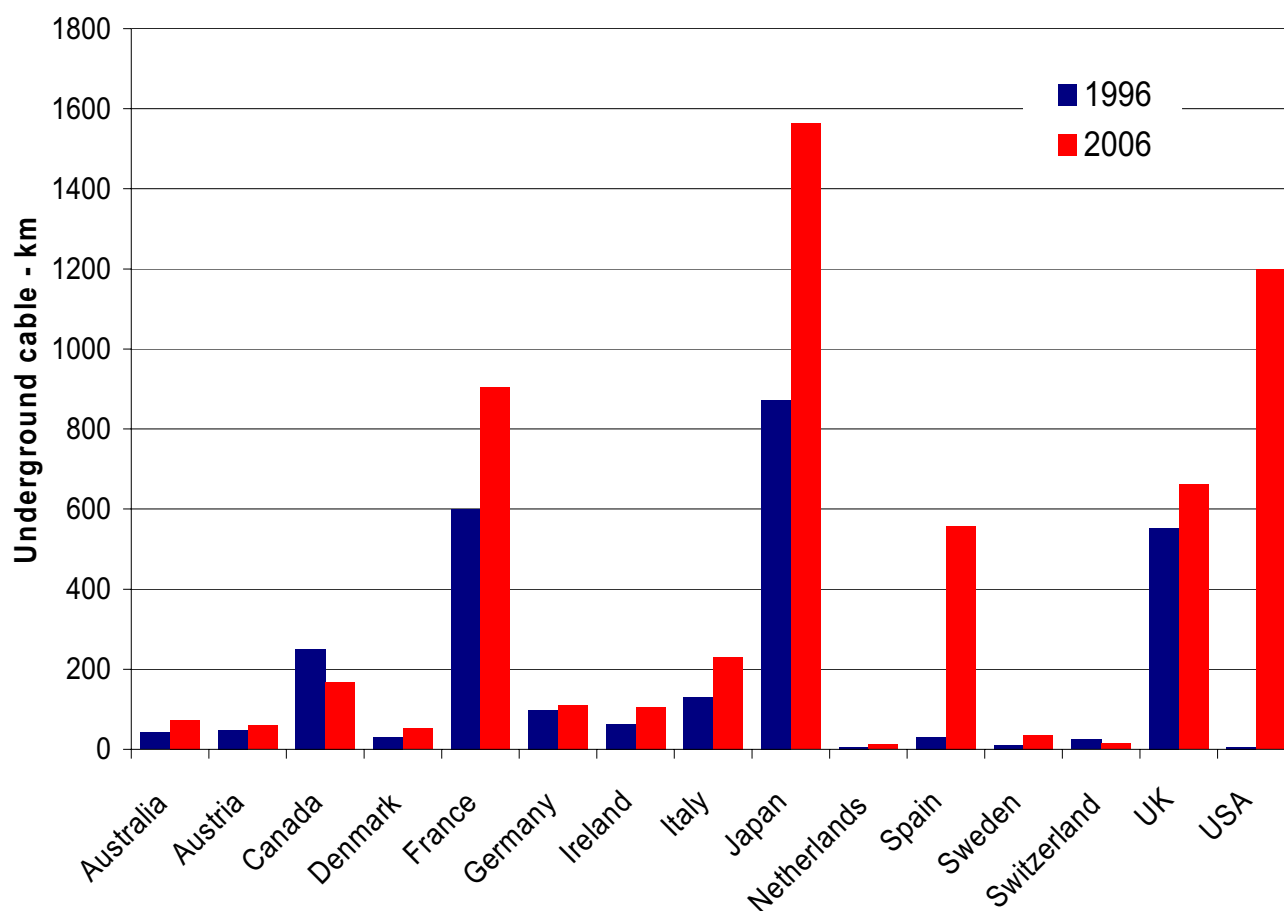

Figure A.3: Total length of ac underground cable installed in the voltage range 220 kV to 500 kV; Comparison of results from the 1996 and 2006 studies.

It can be seen that most countries have reported an increase in the amount of underground cable since 1996, but some of the changes (for example the decreases in cable in Canada and Switzerland and the 20000% increase in cable in the USA) reflect changes in the efficiency of data capture rather than changes in the amount of cable installed.

Areas where there are known limitations to the data are:

Canada – data only from British Columbia, Quebec and Ontario

China - Beijing City only

Germany - based on 2003 data from the German Utility Organisation VDN updated with information from some major utilities

Switzerland –Data from 9 major utilities

Sweden - Data from 5 major utilities

USA - Data from 24 utilities, but these include the largest cable users

Since the data from China only represents the city of Beijing, it is likely to contain a higher proportion of underground cable than would be seen in more rural areas. For the 110-219 kV voltage range Beijing reports 27% undergrounding compared with an international average of 2.9%. For the 220-314 kV voltage range the figure is 8.6% compared with an international average of 1.7%. Although the data for Beijing have been reported in the tables it is not shown in the charts as the Working Group does not consider the data to be representative of all circuits in China. Since the absolute values of the circuit lengths are relatively low they have little effect on the international averages. For example, at 220-314 kV, the international average is 1.66% without the Beijing data and 1.69% if they are included.

Table A.7: Comparison of 1996 and 2006 data for lengths (km) of underground cable in the range 220 kV to 500 kV

	1996	2006	Change
Australia	42	73	75%
Austria	48	59	23%
Canada	250	151.5	-39%
Denmark	31	52	68%
France	600	914	52%
Germany	99	110	11%
Ireland	64	106	66%
Italy	130	231	78%
Japan	873	1563	79%
Netherlands	6	12.5	108%
Spain	31	558	1700%
Sweden	11	35	218%
Switzerland	25	13	-48%
UK	553	662	20%
USA	6	1198.2	19871%

Table A.8: Comparison of 1996 and 2006 data for lengths (km) of underground cable in the range 110 kV to 219 kV

	1996	2006	Change
Australia	679	201	-70%
Austria	485	757	56%
Belgium	140	311	122%
Canada	550	398	-28%
Denmark	210	515	145%
Finland	47	280	496%
Germany	4400	4972	13%
Ireland	84	171	104%
Italy	280	907	224%
Japan	1532	1769	15%
Netherlands	747	1068	43%
Spain	186	181	-3%
Sweden	100	334	234%
Switzerland	400	547	37%
UK	2431	2967	22%
USA	448	2904	548%

## Appendix B THERMAL DESIGN

### *B.1 Load and Ratings*

The rating of a circuit (overhead and underground) is largely determined by the heat produced by the current flowing in the conductor (electrical losses) and the ability of the surroundings to transport the heat away from the conductor. The rating of a circuit is the maximum load (ampacity) that is permitted for the circuit without exceeding the maximum temperature of the conductor. A reduction in losses will increase the rating, and better cooling of the conductor will also increase the rating.

Since the rating is determined by heat production and dissipation it is often referred to as the thermal rating for the circuit. There are a number of different commonly-used thermal ratings depending on how the circuit is operated. These are discussed below.

#### **Nominal rating:**

The nominal or continuous rating is the most commonly used thermal rating. It assumes that the load is constant (or continuous) and the properties of the conductor and the surroundings are known (or are assigned specific values). The nominal rating is the maximum continuous ampacity under specific steady state circumstances.

#### **Cyclic rating:**

Many circuits do not experience a constant load, but one that varies on a regular basis. For example a cable supplying the central business district of a city may experience a high load during the working day, but very little load at night. The maximum current that can be carried in these circumstances is called the cyclic rating.

If the load is varying on a daily cycle it is common to calculate a daily load factor, which expresses the effective load as a 'proportion' of the maximum load.

The daily load factor LF is defined by:

$$LF = [1/(T \cdot I_{\max})] \cdot \int I(t)dt, (t = 0 \text{ to } t = T)$$

T is the time for the cyclic period (e.g. T = 24 hours),  $I_{\max}$  is the maximum actual load current during the time T, I(t) is the load current at the time t.

A constant load has a load factor equal to 1.

#### **Short-term rating:**

A circuit operating below its continuous rating will be cooler than its design temperature. It therefore has the potential to carry a relatively high load for a short period without exceeding its design temperature. The low load during the initial period is called the preload. This is usually assumed to be continuous (or at least to have occurred for a sufficiently long period for the cable to have cooled down). The subsequent short period of high load is the short-term rating, which

depends on the historical load (preload) and the parameter values of the surroundings. The short-term rating utilizes the non-steady-state situation.

**Real-time rating:**

Real-time rating is the maximum load under present conditions. The real-time rating is the maximum load right now, where we take into account the historical data, the actual weather conditions and the thermal resistivities and time constants. Real-time rating can be either a short-term rating or a steady state calculation based on the present situation.

## ***B.2 Nominal Ratings***

If we are going to compare different conductors/cables and different surroundings, it is necessary to define some nominal values of the parameters involved in the calculations. Examples of nominal values of the parameters are shown in the following sections for overhead lines and underground cables.

### **B.2.1 Overhead lines**

Overhead lines are surrounded by air, which is used as insulation and to dissipate heat. Its ability to transfer heat away from the conductor depends very much on the wind speed. The temperature of the surroundings is important, too, but the most important factor is the wind speed.

Factors that influence the ratings of overhead conductors [11,12] are:

- wind speed
- air temperature
- solar radiation
- absorption/emission coefficient
- conductor resistance.

Example of values for calculation of nominal rating:

- wind speed: 0.6 m/s
- air temperature: 20 °C
- solar radiation: 900 W/m<sup>2</sup>
- absorption/emission coefficient: 0.6

The conductor resistance is related to the material used and the dimensions of the conductor.

In the rating calculations we are only interested in the resistive losses. Corona losses are of minor importance.

## B.2.2 Underground cables

Underground cables have resistive losses in the conductor and the sheath and dielectric losses in the insulation. All these losses appear as heat in the cables. Heat has to be transported away from the cable, so the cable will not exceed its design temperature and suffer permanent damage.

The surroundings of a cable system are not uniform and will often change along the cable route. Even in soil with well-defined properties the thermal resistivity will change depending on the moisture of the soil.

In special backfill materials around the cables the thermal properties are well-known, but outside the backfill it is still possible to have material with high thermal resistivity.

In situations with more than one cable system, heat produced by one cable system may influence the rating of the adjacent circuits. Similarly, other external heat sources (e.g. district heating steam pipes) will influence the rating of the cable system.

In cables with very high ampacity forced cooling is sometimes used. For example fans may be used to ventilate cables in tunnels or cooling water pipes can be buried alongside cables in the ground. The rating of these cables depends heavily on the characteristics of the forced cooling system used.

The rating of cables also depends on how the cables are placed (flat configuration, trefoil) and the bonding of the cables (cross-bonded, single-point bonded, solid bonded). See Appendix C.2 for information on bonding.

The rating is also determined by the daily load factor – i.e. if the load is constant or cyclic.

A nominal rating of a cable system can be calculated under well-defined circumstances. Even though a given size of cable does not have the same rating in every installation, it is possible to calculate a nominal rating, which means a rating for a specific cable under specific installation conditions.

Example of typical values used in rating calculations:

- thermal resistivity: 1.0 Wm/K
- direct buried, maximum depth: 1 m
- maximum conductor temperature: 90 °C
- solid bonded
- trefoil formation
- constant load, load factor: 1.



### ***B.3 Short-term Ratings***

The short-term rating is the maximum current/load the circuit can carry for a certain time without exceeding its design parameters. The short-term rating is not constant, but depends on the thermal history and the present situation.

#### **B.3.1 Overhead lines**

The short-term rating of an overhead line can be used for about 15-30 minutes. It is also called the transient load for the line. In the event of a fault on the network, which causes a line to be switched out, another line can be overloaded by a certain percentage (typically 25 %) for some minutes. During this post-fault period the personnel in the control centre have a relatively short time to change the flow in the grid to remove the overload.

For overhead lines designed to a maximum sag it is not possible to make use of the short-term load for a longer time, because the sag of the overhead line will be too great. The design temperature of a conventional ACSR (Aluminium Conductor Steel Reinforced) conductor is typically 50-90 °C.

If the towers are sufficiently tall, the sag of the conductors will cause no problem, the limit of the short-term load is determined by the maximum temperature of the conductor. The maximum long-term temperature for a conventional ACSR conductor is 75-90 °C. For shorter periods the temperature is limited to about 120 °C. Higher temperatures will anneal the aluminium which will lose much of its strength. High-temperature conductors can operate at temperatures up to for example 150 °C or 250 °C.

Overhead lines can be designed for different temperatures, and each line has its own limits. Under normal conditions the load is much lower than this load limit (for example 50 %). In a situation where the load rises above the long-term load limit, there is only 15-30 minutes to correct the situation.

### B.3.2 Underground cables

Underground cables are normally limited by the conductor temperature. In paper-insulated cables the maximum conductor temperature is typically 60-90 °C (depending on cable type) and in XLPE-insulated cables the maximum conductor temperature is 90 °C.

If the continuous load results in a steady state situation with conductor temperature equal to the maximum conductor temperature, this load is called the rated load,  $I_{rat}$ , of the cable system. Under normal grid conditions the actual load,  $I_{act}$ , will be much lower.

For example, if  $I_{act} = 0.5 * I_{rat}$ , the actual conductor temperature is below the temperature limit. In this situation a parallel line may be switched off and the actual load rises to for example 25 % over the steady state limit. This means  $I_{act} = 1.25 * I_{rat}$ .

Because of the long thermal time constants of the cable and the backfill etc. it will take some hours before the temperature limit of the conductor will be reached. This means that the short-term load of the cable is large and that it can be used for several hours – and sometimes for a few days. The magnitude and duration of the short-term load is determined by the historical data (the preload) and the thermal time constants of the system.

The principle of the short-term load is shown in Figure B.1. In this example the preload is below 50 % of the nominal (continuous) rating. A fault in the transmission network results in a sudden rise of the load to about 4 times the preload for a short period. This short-term load, which is almost the double of the rated load, can last for some time - until it 'hits' the short-term load capacity curve in the figure. It can be seen that the magnitude of the short-term rating is highly dependent on the duration of the overload period.

Because of the relatively long duration of the short-term load it is possible to make use of the short-term load in a daily planning situation in the control centre. In the case of system security calculations (e.g. N-1 calculations, where no line in the grid may be overloaded when another line is switched off), the maximum load of a cable system can be the short-term load for some hours – perhaps 24 hours. The preload can be the expected load or a conservative assumption.

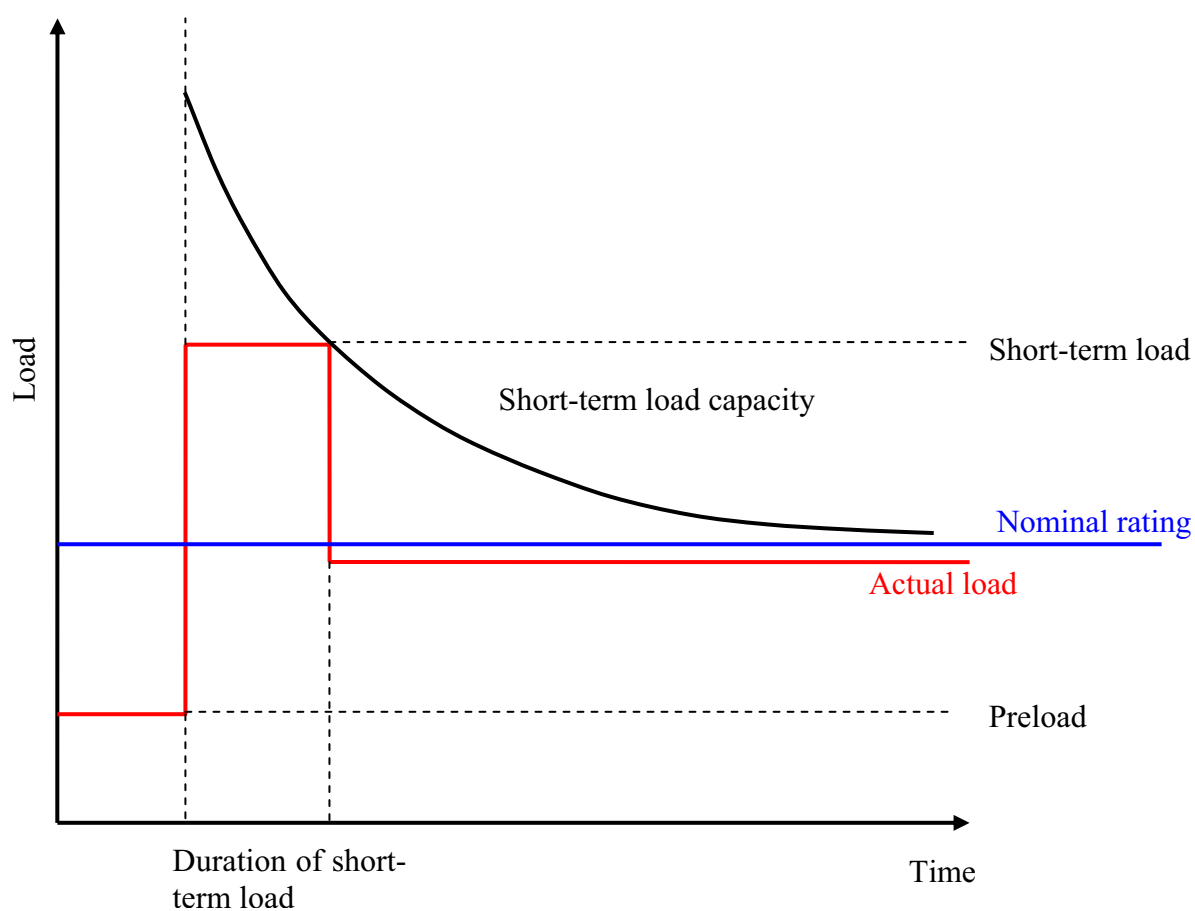

**Figure B.1:** Utilisation of short-term load under operating conditions.

It is not possible to make recommendations regarding short-term ratings that can be used generally. The grid and the way it is operated differ from country to country, so the utilisation of the short-term load will not be the same. Nevertheless there is generally a high amount of reserve built into the cable and the surroundings that can be utilized.

#### ***B.4 Real-time Ratings***

Real-time rating is the maximum load under actual conditions, taking into account the historical data, the actual weather conditions and the thermal resistivities and time constants.

The real-time rating cannot be used in predictions or for day-to-day planning purposes, but it gives the operator a real-time calculation of the capacity of the line. This will help him in an operation situation, where the reserves in the grid will be used. It is also possible to get closer to the limits when he is planning for the next day, because the circuit is monitored.

For overhead lines, real-time ratings can be produced by measuring the conductor stress, the conductor temperature or the sag.

Real-time rating on underground cables can be assisted by measuring the temperature along the cable (see Appendix E2.3). The real-time rating calculation must be based on thermal models, where the input is the historical load and perhaps the temperature of the surroundings.

### ***B.5 Prediction of Ratings***

For planning and operational purposes, it is important to know the rating of all circuits. In order to ensure that the capacity is there when it is needed, conservative estimates are often used. This means that there is a risk that the full capacity of the grid is not utilized. If it is possible to predict the rating of a line in such a way that the security is still available, the grid can be utilized in a more optimised manner.

#### **B.5.1 Overhead lines**

The rating of overhead lines is heavily dependent on the weather conditions. At night there may be no wind, but some hours later in the morning the wind is blowing. The rating difference between the two situations can be a factor of 2.

It is possible to predict the (average) wind speed some hours or even days before. But it is impossible to predict precisely when the wind speed for example rises from 1 to 6 m/s. This is a problem in the prediction of rating for overhead lines. If the weather conditions are known in detail the day before, it is possible to use this in a day-to-day planning situation in the control centre.

#### **B.5.2 Underground cables**

It can be easier to predict the rating for underground cables. Especially for new cable systems it is possible to collect information about the surroundings, so it will be possible to make better calculations of the ratings.

The surroundings of new cable systems are generally well-known and they will only change slowly with time. It is therefore possible to predict the rating of an underground cable system. This can be used in the day-to-day planning, so the cable system in fact can be better utilized.

### ***B.6 Ratings of hybrid overhead/underground networks***

Overhead lines and underground cables must be able to cooperate in the grid. There are inequalities between overhead lines and underground cables, which at first may cause problems, but these differences may result in different ways of dimensioning lines.

Overhead lines normally have a high nominal rating, but they have a short-term rating that can only be used for 15-30 minutes. It is difficult to predict the maximum rating for an overhead line, because it so much depends on the weather conditions.

Underground cables often have a smaller nominal rating, but they have a relatively high short-term rating, which can be utilized for hours. It is relatively easy to predict the maximum rating for an underground cable system, because the conditions of the surroundings only change slowly.

It is possible to make use of the short-term rating of cable systems in the day-to-day planning. This can also be taken into account in the long term planning of the grid.

The situation with a mix of underground cables and overhead lines is discussed in more detail in Technical Brochure 250 [4].

Where part of a circuit is underground, we have overhead lines and cables in connected in series. This means that the same current has to flow through both the overhead line and the underground cable, and that the rating of the cable circuit should match the overhead line.

If the cable system has the same nominal rating as the overhead line, it will be the overhead line that is the bottleneck in the circuit, because the cable in real life has a short-term load for hours that exceeds the rating of the overhead line. The cable also has an emergency load that will not be used in this case.

To match the cable and the overhead line it is recommended to take into account the daily load factor. Theoretically it can be 1, but in practice it is likely to be between 0.7 and 0.9 depending on the nature of the line (transmission or distribution line).

The operator of the grid will not run a circuit with maximum load under normal circumstances, because a fault in the grid will then cause an overload of this circuit. Instead the circuit might be loaded by for example only 50 %. This preload situation means that there is a high short-term load available for a cable.

The overhead line can be built with a high intrinsic rating, which is perhaps not utilized in the early stages of its life. The extra cost of achieving a high rating for an underground cable generally means that these are designed to meet the demands of the present and the near future, not necessarily those in 40 years time. If there is space available to install an extra cable circuit later, it may be cost effective to install a low power cable now and add another circuit when it is needed.

For every cable installation in the grid the daily load factor and the preload conditions must be analysed. It is not possible to give any guidance that will cover all situations. The owner of the line or the Transmission System Operator has to make its own assumptions to match the rating of the cable to the overhead line.

## **Appendix C      ELECTRICAL DESIGN**

### ***C.1 Protection***

An automatic re-closure system is used on an overhead line to re-energize the line in the case of transient faults, such as lightning strikes. Re-closing is not used on underground cable systems because transient faults on cables are extremely rare. Automatic re-closing on cables, particularly on oil-filled cables, can cause an explosion or fire with attendant risk to the public and the environment. In addition, unnecessary short circuits on the grid should be avoided.

In the case of hybrid circuits, with both overhead and underground sections, it is possible to provide unit protection devices (differential/zone) to ascertain which section has failed. If the cable section fails, re-closure is inhibited. The technique is simple but needs a lot of equipment including telecommunication channels towards both ends. This makes the protection expensive and it can be an option to accept re-closure on the cable if the risk is deemed acceptable.

### ***C.2 Special Bonding***

Different methods of bonding the metallic screens or sheaths to earth may be chosen when designing a cable system. The usual bonding methods are described below:

#### **Solid bonding**

A solidly bonded cable system has both ends of the sheath connected to earth (figure C1). In this arrangement the metallic screens or sheaths provide a path for circulating currents under normal operating conditions. This will cause losses in the metallic screen, which reduces the cable's current-carrying capacity. These losses are smaller for cables in trefoil formation than for cables in flat formation with separation. In principle solid bonding is the simplest form of earth connection, resulting in low maintenance requirements, but is generally used for cable connections having a relatively low load current.

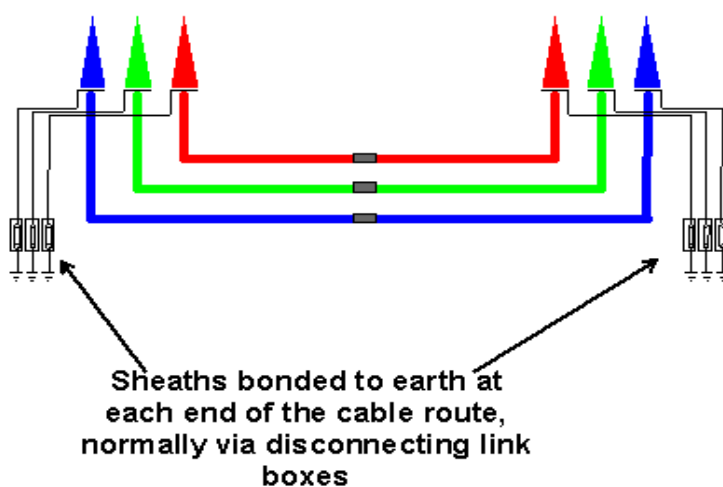

Figure C.1: Solid bonding of metallic screens or sheaths

### Single-point bonding

A system is single point bonded if the arrangements are such that the cable metallic screens or sheaths provide no path for the flow of circulating currents or external fault currents (figure C2). In such case, a voltage will be induced between screens of adjacent phases of the cable circuit and between screen and earth, but no current will flow. This induced voltage is proportional to the cable length and current. Single-point bonding is preferred for short terminal-to-terminal runs and line taps and in principle for those circuits with not more than one joint. A parallel earth continuity conductor (ECC) is installed to ensure a well defined path for the return of fault currents to the system neutral.

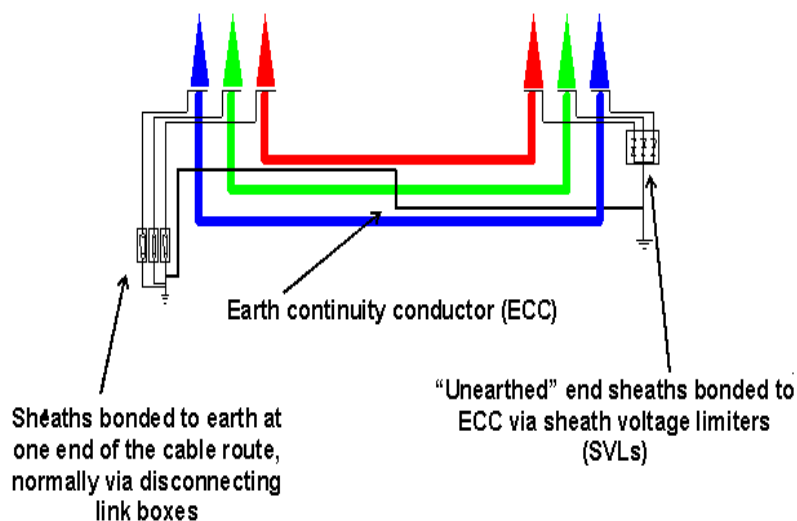

Figure C.2: Single point bonding of metallic screens or sheaths

## Cross-bonding

A system is cross-bonded if the arrangements are such that the circuit provides electrically continuous sheath runs from earthed termination to earthed termination but with the metallic screens or sheaths so sectionalized and cross-connected in order to eliminate the sheath circulating currents. See figure C.3. In this case, a voltage will be induced in between screen and earth, but no significant current will flow. The maximum induced voltage will appear at the link boxes for cross-bonding. This method provides a cable with the high current-carrying capacity of a single-point bonded cable, but offers longer route lengths. It requires screen separation and additional link boxes.

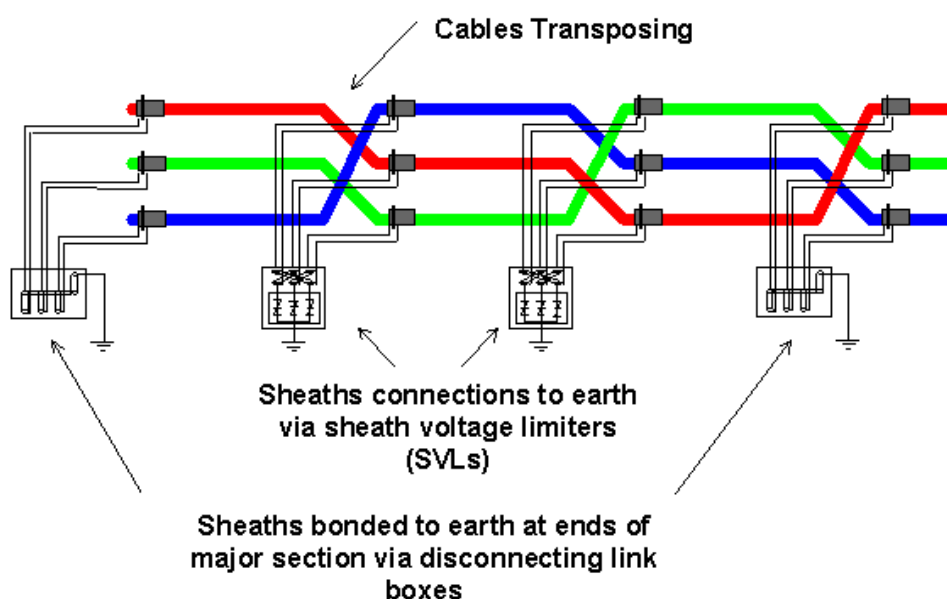

Figure C.3: Cross bonding of metallic screens or sheaths

Further information on special bonding systems is given in three Electra papers [13-15] and a Technical Brochure [16].

### *C.3 Parallel lines*

When an overhead line and an underground cable of the same transmission capacity operate in parallel, most of the load will flow in the cable due to its much lower impedance. Because of this, the cable reaches its current limit much earlier than the overhead line.



This problem can be solved by using a cable system with a larger transmission capacity or by increasing the impedance by the use of a series reactance. At the planning stage, the load distribution between the underground cable and the parallel overhead line must be analysed.

### ***C.4 Reactive Compensation***

Overhead lines are largely used in transmission networks due to their technological simplicity, low costs and suitability to transmit bulk power for long distances (100 to 300 km). Their main intrinsic feature is a high ratio between inductive and capacitive reactance, physically represented by the characteristic impedance of the line.

The characteristic impedance of underground cable systems is much lower, due to differences in both inductance and capacitance. At first glance, the insulated cable capacitance is at least 15-20 times while the inductance ranges between 0.25-1 times those of overhead lines. As a consequence, the capacitive reactive power of a cable system becomes a sensitive factor to be taken into consideration particularly for the highest voltages, see table C1.

Table C1. Indicative figures for the reactive power produced by transmission circuits under no load.

V [kV]	Transmission	Conductor	C [ $\mu$ F/km]	L [mH/km]	Q <sub>C</sub> [Mvar/km]
66	Overhead	524 Al	0.010	1.440	0.01
66	Underground	300 Cu	0.178	0.768	0.2
150	Overhead	Steel/Al 52/591	0.011	1.115	0.1
150	Underground	1200 Al	0.191	0.592	1.3
400	Overhead	Steel/Al 92/591	0.015	0.800	0.7
400	Underground	2000 Cu	0.200	0.756	10.0
400	Underground	2500 Cu	0.240	0.724	12.1

In consideration of the length of the cable circuit and the transmission system characteristics, it may be possible that a shunt inductive reactance needs to be applied in order to compensate for the high capacitive reactance of the cable system.

Case studies conducted on some 400 kV transmission grids show that the characteristics of cables may be in many cases beneficial to the general behaviour of the network. For example, the high electrical capacitance of cables contributes to increased voltage collapse margins of substations. However, when the ratio of underground to overhead become too high, compensation becomes necessary, especially during periods of low load. At that moment, both overhead lines and cable systems show a predominantly capacitive character.

The application of shunt reactors may be necessary for three main reasons:

- Compensation for high capacitive current (optimization of efficient transmission capacity)
- Voltage control of the network
- Black start (for power stations with long cable connections)

Moreover shunt reactors improve the energy transmission efficiency and flexibility. They should preferably be installed at the extremities of the connection. In some cases for very long cables connected to overhead lines, it may be necessary to install shunt reactors at the overhead/underground transition point. The installation of shunt reactors in the middle of very long cable circuits is in principle not recommended. Figure C.4 shows a three phase 400 kV shunt reactor. It weighs 160 tonnes and its dimensions are approximately 9 m x 6 m x 9 m.

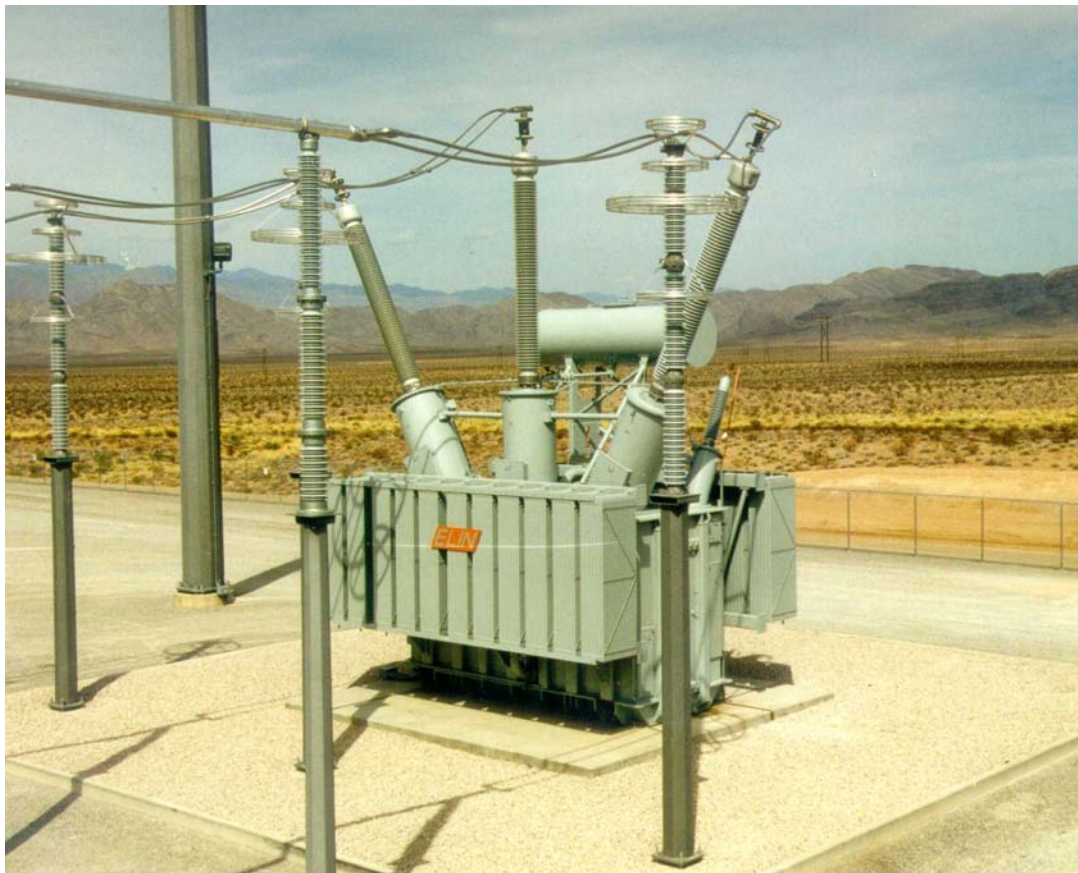

Figure C.4: Three phase 400 kV shunt reactor (rated 160 MVar)

## Appendix D CONSTRUCTION AND INSTALLATION

### *D.1 Laying Techniques*

There are 3 main functions to be considered for the design of a cable laying technique:

- Thermal design: the heat produced by the cable must be dissipated
- Mechanical protection from and against third parties
- Ensure the safety of the public and of those working near HV circuits.

In the event of a short circuit of the cables, mechanical stresses are very high and the cables have to be restrained. Buried cables must be installed at such depth that any resulting disturbance is not noticeable at the ground surface. It may also be necessary to install protection around the cable.

In addition, external environmental requirements, for example limits on the duration of civil works (opening of the trench) must also be considered. Many countries have legal requirements regarding the dimensions of the trench and safety considerations.

In August 2001 CIGRE WG 21.17 published a Technical Brochure [17] on construction, laying and installation techniques for cable systems. Twelve cable laying techniques were listed as being used to varying degrees by different companies around the world. Among those twelve techniques, three are commonly used world-wide: laying in ducts, direct burial, and laying in troughs. They have been successfully used for many decades due to their simplicity, relatively low cost, the availability of materials and equipment as well as qualified contractors to execute the necessary work. Consequently those techniques are the most suitable to be compared with overhead lines. The other techniques are used in specific situations for example drilling under local obstacles (roads, rivers and railways) or tunnelling relatively long links in congested urban areas.

#### **D.1.1 Laying in Ducts**



Ducts are normally used with manholes in a system that is favoured in urban areas of major cities for its convenience.

They offer the possibility of carrying out the civil work independently from the electrical work. In addition, the flexibility of cable installation, maintenance or replacement with minimum disturbance to local traffic and economic activities are considered advantageous.

Three or more ducts having the required diameter

and wall thickness are placed in a trench at the pre-determined depth and configuration. A layer of special bedding material having low thermal resistivity is placed on the bottom of the trench prior to laying the ducts. Ducts can also be stacked in two or more layers to accommodate the required number of cables. Special spacers are used to ensure the exact configuration and to allow concrete to flow between ducts.

In some cable sections, the space between the cable and the duct is filled with special materials to enhance cable current carrying capacity or restrict its movement. This is recommended in excessively deep installation or when difference in elevation between manholes is substantial.

Laying cables in ducts is considered one of the safest types of installation regarding safety in case of a short circuit. It should be noted that a good earth cover over the duct bank is necessary to ensure public safety.

### D.1.2 Direct Burial

This method consists of digging a trench and directly placing the cables in it. This solution is particularly interesting economically, since apart from digging and backfilling the trench no other heavy works are necessary. This is why the technique is used in urban as well as in rural areas.



In some areas it is necessary to support the trench with shuttering (side walls) for safety or environmental reasons.

Where soil characteristics and safety concerns permit, civil works contractors are increasingly suggesting the use of a U- or V-shape trench (without side walls). This can result in a significant reduction in the costs and the duration of the civil works.



An advantage of this method is that the route of the link can easily be deflected to avoid unforeseen obstacles during construction. The depth of the trench is such that in most cases the cables have an earth cover at least one metre thick. (This often is a legal requirement and can also depend on short-circuit levels).

Trench width obviously varies according to the type of formation and the voltage level of the cables:

	60 to 170 kV	220 to 500 kV
Trefoil formation	< 0.8 m	close to 1.0 m
Flat formation	close to 1.0 m	> 1.0 m

Cable-protective slabs are placed over the backfilling material.

### D.1.3 Troughs

A trough is generally a prefabricated U-shaped covered housing which is used to protect the installed cable from mechanical damage.

The trough can be constructed from pre-cast sections, approximately one metre long, installed end to end or can be cast in-situ by means of a continuous concrete casting process. In both cases the tops of the sides are rebated permitting a structural cover (typically of concrete, steel or fibre reinforced plastic) to be used to protect the cable.

Once the trough path has been assembled, the cables may be installed as in an open trench, either by a pulling or a laying process from joint to joint or from joint to termination.

The troughs are sometimes filled with sand or weak-mix concrete to aid heat dissipation. If the cables are in air they may need to be fixed with steel cleats to restrain the cable during short-circuit faults.

Finally the trough covers are fitted.

Presently, this type of laying technique is mostly used inside substations or other closed and protected sites.

#### **D.1.4 Bridges**

It is common to use existing bridges where the cable route crosses rivers, railways, road junctions etc. Some bridges have a natural space for placing cables, either inside the bridge or in the sidewalk.



The photograph shows cable ducts suspended beneath a bridge.

Before deciding to use an existing bridge as a crossing, a careful study should be made. The designer has to take into consideration the dynamic mechanical stress caused by its vibrations, elongation and bending at junctions and the environmental stress such as wind pressure and heat from solar radiation

### D.1.5 Shafts

Shafts are generally used in hydro-electric generating plants where the power generated by underground equipment has to be brought up to the beginning of the overhead lines.

Shafts may also be part of cable routes in cities where the cables are running in deep tunnels and must be connected to lines or substations



### D.1.6 Horizontal Drilling

Guided horizontal drilling, sometimes referred to as guided boring, is a construction technique that may provide faster cable installation with less disruption to the surrounding urban and suburban neighbourhood.

Drilling can be initiated from a rig either placed into a pre-dug launching pit, or mounted on the road or soil surface. The following drawing outlines the procedure commonly followed to install a duct bundle:

PRINCIPLE HORIZONTAL DRILLING

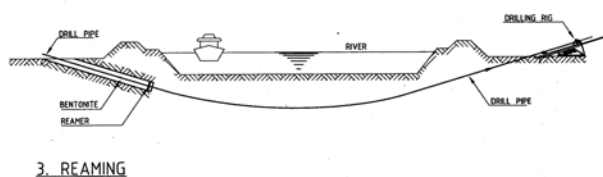
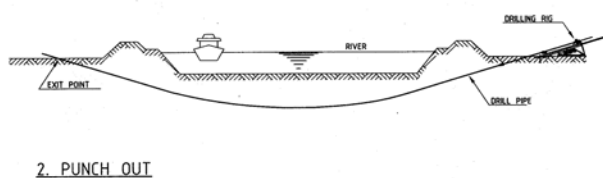
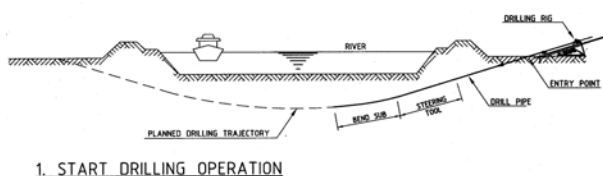

PRINCIPLE HORIZONTAL DRILLING

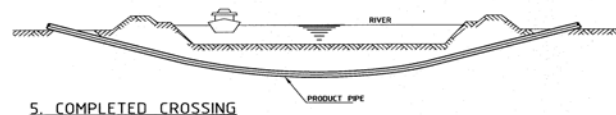
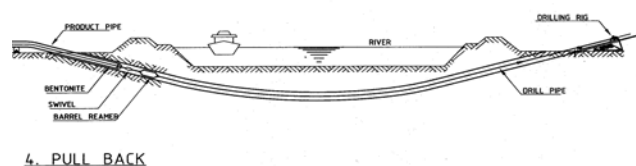



Depending on the underground environment, the required hole diameter (number of pipes to be installed) and the depth of installation, the maximum practical length of the horizontal drilling can vary from 20 m up to 900 m.

### D.1.7 Pipe Jacking

There are three different pipe jacking techniques:

- i) Jacking by beating or pneumatic rocket
- ii) Jacking by rotation
- iii) Jacking by thrust

The last technique is the most commonly used.

Pipe jacking can be considered as an environmental balanced installation technique, as it does not affect the surroundings.

The surplus soil (equal to the volume of the pipe) is removed from the ground implying that displacement of the in situ and settled soil can be avoided.



The nature and composition of the soil must be investigated before the pipe jacking method is selected. Pipe jacking is not applicable in hard soil such as limestone, sandy shale or granite. Pipe jacking is not recommended in heterogeneous soil with large inclusions (clay with flint or alluvium containing boulders).



Pipe jacking is possible up to a length of 100 m without intermediary stations. With intermediary stations lengths up to 500-600 m may be installed, but the work is limited by the time required to transporting backwards in the pipeline.

### **D.1.8 Microtunnels**



Similar to the pipe jacking method this technique also consists of pushing prefabricated tubes in the subsoil. The earth works at the front of the tubes, however, are systematically mechanised using a so-called microtunneller, i.e. a steerable drilling device, which will penetrate harder subsoils than is possible with simple pipe jacking.

Microtunnel diameters are typically between 300 and 1200 mm and their lengths a maximum of 200 m.

In contrast to larger tunnels they are not accessible by man and mostly contain only one 3-phase power cable system.

### **D.1.9 Embedding**

This technique consists of excavating a riverbed from a barge or with an amphibious machine, burying a duct or cables and filling up the trench.

The depth of cable burying and the type of protection are defined by considering the potential mechanical damage (for example from anchors).

### **D.1.10 Tunnels**

For relatively long links in urban areas, the use of tunnels is sometimes considered. A cable tunnel can be used where a number of circuits must be installed along one particular route, when it is difficult to secure the required transmission capacity using direct burial or ducts.



A tunnel can be constructed using the open-cut method, shield method, or pipe jacking method. The pipe jacking method was described in Section D.1.7 above.

In an open cut tunnel, the ground surface is excavated first, then the tunnel is constructed at the required location, and finally ground surface is restored using backfill. Although a relatively low cost tunnelling technique, the open cut method cannot be used where traffic is heavy, or where there are many underground services such as telephone cables, gas pipes, water pipes, sewage pipes, subways, etc.

The most commonly used method of tunnel boring uses a full face boring machine. This is a cylindrical machine with teeth on the front face. Waste is removed from the rear.

The shield method can be used when the subsoil is poor. A shield tunnel is excavated by a tunnel driving machine known as a "shield machine" and tunnel walls are constructed by fixing pre-fabricated circular pre-cast members called 'segments' against each other using bolts. Circular tunnels with diameters from 1.80 m up to 14 m have been constructed in Japan.

Generally, shafts have to be built between the different sections of tunnels. Ventilation is generally used in tunnels for human safety. Ventilation also dissipates the heat generated by the cables, thus increasing the transmission capacity compared to direct burial or ducts. When larger transmission capacity is required, a cooling system may be applied.

### **D.1.11 Use of Existing Pipes**

Finding new routes for HV cable circuits is becoming increasingly difficult, especially in urban or conservation areas. The use of existing pipes is very attractive to solve integration problems in the landscape and may lead to drastic reductions in cost and start-up delays.

This mode of installation offers several advantages including the use of short and narrow roadway openings, which minimising traffic disturbances. Generally, we can consider that this technique offers the same advantages as installation in ducts.

### D.1.12 Mechanical Laying

This technique, developed from the traditional trench technique, is suitable for buried cables. It consists of opening the excavation and simultaneously laying the three phases, (and possibly earthing cable and telecommunication cable as well) and backfilling.



When combined with the use of weak-mix mortar it offers:

- good cable protection from external damage
- good control of the direct heat environment of the cable
- good protection of the environment in case of short-circuit
- reduction of the size of the trench compared with conventional technique
- reduction of work duration.

A few conditions are necessary to allow the use of this technique:

- rural land with few obstacles
- routes more than a few hundred meters long
- inclines of less than 25%.

The use of this technique is consequently limited. Trial installations have been undertaken with 90 kV cable circuits.

## ***D.2 Installation Methods***

The most commonly used methods are nose pulling followed by power rollers, caterpillars, bond pulling and finally mechanical laying. A brief description of each of the four techniques is given below. Mechanical laying, being simultaneous installation and laying was covered in D1.12 above.

**Nose pulling**

With this technique the cable is installed by using winch with a pulling hawser directly connected to the cable end, or 'nose'. The tension required to install the cable is taken by the cable itself and hence it is important that the pulling tensions are calculated beforehand to ensure the design limits are not exceeded.

**Bond Pulling**

With this technique the pulling tension applied by the winch is taken by a wire bond to which the cable is tied at regular intervals.

At bends the bond is passed through a snatch block and the ties attaching the cable are removed before the bend and reapplied after the bend in a continuous operation.

The tension required to install the cable is therefore distributed along its full length and sidewall pressure at bends is reduced to a minimum.

**Synchronised power drive rollers**

This technique relies on the use of multiple powered rollers positioned at regular intervals along the cable route to install the cable. The frequency of the rollers is dependent upon the cable construction and the route itself.

Since each roller has to provide an equal force they have to be synchronised to operate effectively and to avoid any damage to the cable due to compressive forces.

Normally a winch and hawser are used to supplement the rollers by nose pulling but the tension on the cable end is very low due to the driving effect of the powered rollers.



### **Caterpillar or hauling machine**

Caterpillars apply a pushing force directly onto the cable outer sheath and can be used to install the cable directly or in conjunction with power rollers or winches.

### **Pushing-floating**

A laying method has recently been trialed in France (for more information, see Appendix G: Locmalo – Plouay Link). The technique was inspired by the use of compressed air to blow fibre or telecommunication cable into pre-installed ducts.

Power cables were laid in HDPE ducts directly buried in the soil. The innovative pushing-floating technique using pressurised water in place of compressed air.

In addition to providing a degree of buoyancy, the fluid injected into the ducts avoids the sticking effect caused by the electrostatic field (PE cable outer sheath on PE duct) and friction heating.



Friction is considerably reduced. The floating effect (cable pushed by water flow) is combined with a mechanical pushing effect (caterpillars at the duct entry point) and may be improved by a classical pulling shuttle head. The stresses on cables are greatly lowered. Cable lengths between joints can be increased. This may be possible on more complex routes.

The results of this experiment were as follows:

- the number of joints was decreased by a factor 3. (Some sections of cable are as long as 3.3 km).
- the cables were modified in order to produce such long sections: the aluminium screen was transversely welded and tests were carried out in order to qualify this specific feature.
- the duration of the cable pulling was decreased (on average 19 m/min).

These results highlight an interesting alternative to conventional methods, and further studies are being considered to confirm whether the technique would be effective and economical on more complex cable routes.

### ***D.3 Environmental Considerations***

Overhead lines and underground cables have different impacts on the environment. The impact of underground cables is most significant during the construction phase as can be seen above. Environmental impacts are only considered briefly here as they have been reported extensively elsewhere (for overhead lines [18-21] and underground cables [4,22]).

#### **Length of routing**

In urban areas, cables are usually laid in the public domain by running them along existing roads. In rural areas, where the road network is sparse, retaining this practice leads to underground links that are generally longer than the equivalent overhead lines.

#### **Cable laying and obstacles**

Unlike overhead lines, the installation of underground links is greatly influenced by the ground in which the trench must be dug (for example, rocky soil makes cable installation difficult) as well as any obstacles that have to be crossed.

#### **Landscape**

The impact of an overhead line on the landscape is immediately perceptible and, despite the efforts devoted to optimising line design and routing, an overhead line will always remain an artificial part of the landscape that is sometimes visible from great distances away. Obviously, the same is not true for an underground cable except during laying. Where an underground section is included in an overhead route, the transition site may have a significant visual impact.

#### **Land use**

The works related to overhead lines only have significant impact around the location of towers, whilst those concerning underground cables have a greater influence on the total route of the link, although work is not necessarily carried out at the same time along the entire route).

After installation work is complete, cultivation of the ground is allowed in both cases. For the overhead line it is only the towers that hinder cultivation. However the presence of an underground cable can be a problem along the route. For example it is not possible to plant trees, which develop extensive root systems.

Although it is entirely possible to build underneath lines, people are becoming more reluctant to live beneath overhead lines. On the other hand, the presence of a buried cable is incompatible with any permanent construction above it.

### **Electromagnetic fields**

It is important to note that an electric field is present around overhead lines, whereas for underground cables, the electric field is almost completely confined inside the earthed metallic screen.

High electric fields can produce radio interference and audible noise, which may be unpleasant for those who live near an overhead power line. These effects are generally only significant at 220 kV and above. The impact can be reduced by selecting appropriate design parameters [28,29].

The magnetic field produced by overhead lines and buried cables are of the same order on the axis (that is directly below the overhead line and directly above the cable, the difference being that the magnetic field of the overhead line diminishes much more slowly than that of the buried link as you move away from the circuit. With a buried cable the magnetic field becomes very low at only a few metres away from the axis of the cable system.

Take the example of a single 150 kV circuit carrying a current of 1000 A. The magnetic field calculated at a height of 1 metre above the ground is shown in figure D1 for a range of overhead and underground configurations. For the underground cable three configurations are considered: trefoil, flat (i.e. horizontal) and vertical. The cables are buried at a depth of 1 metre (to the axis of the upper cable) with a separation of 0.12 m between the cables. To show the strong influence of cable separation the field due to cables in flat formation 0.3 m apart is also shown. Magnetic fields from the overhead line are calculated assuming the conductors are 10 m above ground level in either vertical or flat formation.

The magnetic field from overhead lines calculated at a height of 1 metre above the ground will be highest where the cables are nearest to the ground (usually about midway between towers) and will decrease towards the towers. Underground cables are generally installed at a more uniform distance from the ground surface, resulting in a more uniform magnetic field along the cable route.

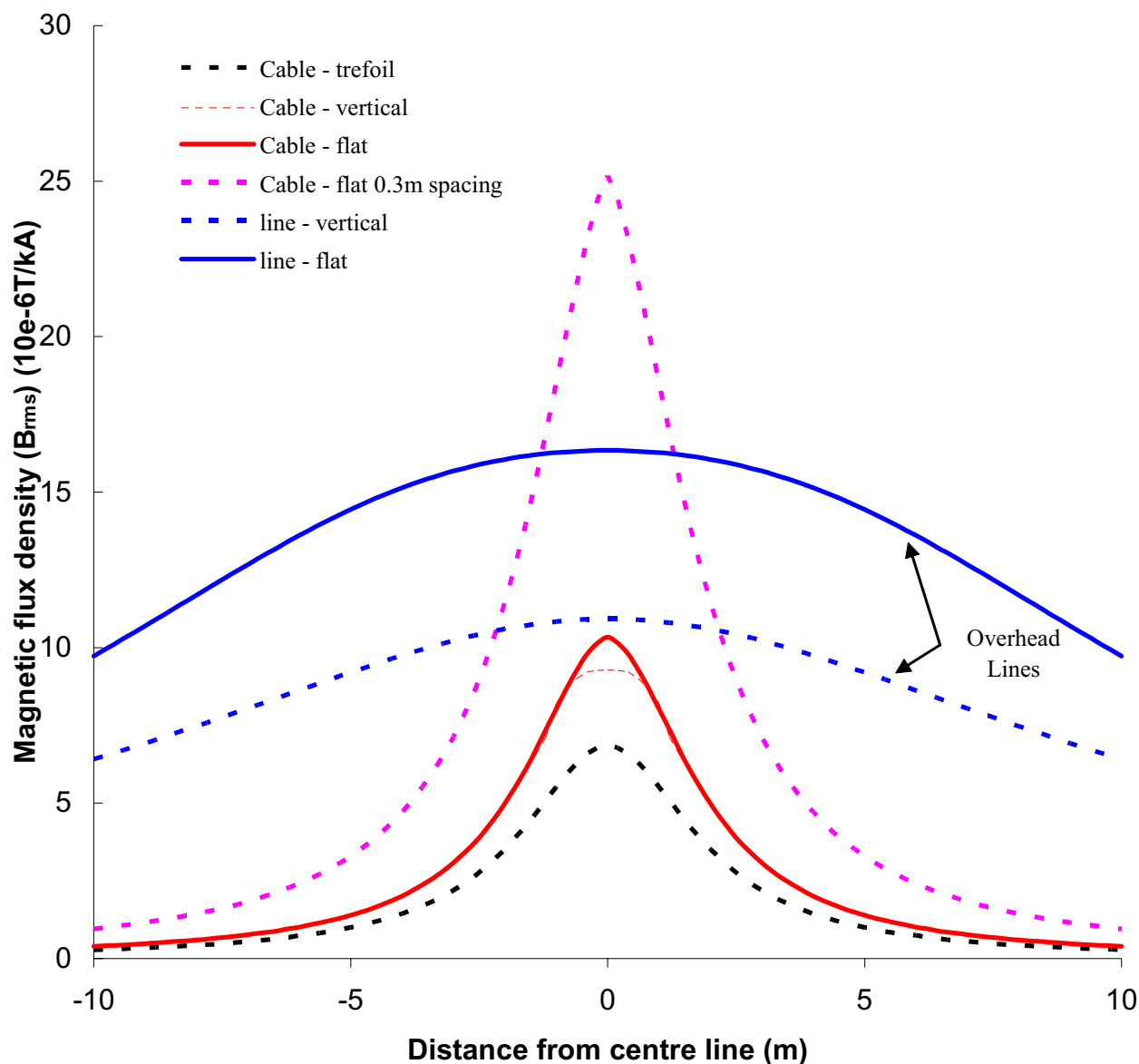

Figure D.1: Magnetic flux density profiles for underground cables in trefoil, flat and vertical formations and overhead lines in flat and vertical formations

The values given in Figure D.1 cannot be applied directly to other situations, because magnetic fields are known to be sensitive to many parameters (order of the phases, number of circuits, current in the screens or groundwire(s), configuration of the cables, etc., all of which may significantly affect the values. Further guidance on the calculation of magnetic fields from cables has been published by CIGRE Joint Task Force 36.01/21 [23,24].



## Appendix E OPERATION

### *E.1 Uprating*

Uprating is term used for a range of techniques which allows more power to be transmitted through an existing overhead line (OHL) or cable system. This can be done with or without hardware changes. Uprating without hardware changes is mainly based on probabilistic calculations or changed assumptions (re-assessing). CIGRE Working Groups have carried out extensive reviews of techniques for uprating overhead lines [25,26] and underground cables [22].

#### **E.1.1 Uprating Overhead Lines**

##### **Maximum conductor temperature**

The ampacity of an overhead line is determined by the maximum conductor temperature. This depends on the heat production in the conductor, the ambient temperature, the wind speed and solar radiation and absorption factor. OHL are not always used with the maximum allowable conductor temperature, because of the risk of annealing or due to legal limitations. In cases where the conductor temperature is not limited by considerations of electrical clearance, there is a possibility for uprating.

##### **Use of probabilistic ampacity calculations**

The maximum ambient temperature in the ampacity calculations is a probabilistic value. When there is enough distinction between the temperatures during the seasons, this can be used for temporary uprating during a part of the year.

Another method is uprating by increasing the maximum conductor temperature above the long term allowable temperature for a short period of time. For some conductors (especially ACSR) this hardly causes any permanent conductor sag. (Indicative values: ACSR long term operation: 90°C and short term, 15-30 minutes: 105°C).

##### **Real time monitoring and thermal rating**

By measuring the actual conductor temperature and taking the weather-forecast into account it is possible to predict the ampacity for the coming hours. The same can be done by measuring the tension of the conductor. This method of uprating is only useful for short and medium-term operations.

##### **Re-conductoring**

This is the most common way to obtain a large increase of the power carrying capacity (indicative value: 30% up to more than 100%). There is a wide range of conductor types available, but depending on the type of conductor chosen the towers may have to be reinforced.

Some conductor systems have been specially developed to facilitate uprating:

Compact conductors have been developed to increase the reliability of OHL with weak towers, but can also be used for more ampacity when the towers are strong enough. Compact conductors have more conducting material at the same diameter, this means a greater ampacity and lower losses. Compact conductors are widely applied.

High temperature conductors can be used to achieve a much higher operating temperature than conventional conductors, with almost the same sag. The higher allowable temperature gives more ampacity with the same tension at the towers. The disadvantages are higher price and much higher losses.

Uprating can also be done by installing more conductors per phase. More conductors cause more wind drag and normally require reinforcement of the towers.

### **Sag compensators**

The ampacity of an OHL is often restricted by a thermal limit reached when the expansion of the conductor increases the conductor sag so that it reaches the limit for electrical clearance. Mechanical sag compensators can solve this problem. At the same time the tension at the towers become lower. By pulling up the conductor an opportunity arises for a higher allowable current.

### **Increasing tower height**

The same effect as sag compensators can be reached by increasing the tower height.

### **Voltage uprating**

This is a very effective method of increasing power capacity (indicative: 100 to 300%), but is not commonly used. In some cases it is possible to modify the towers and make them appropriate for a higher voltage level. Issues to be addressed are distances (phase to phase, phase to earth, phase to object), creepage distance, protection against lightning, corona and the width of the safety strip.

Voltage uprating without a complete replacement of the tower leads in general to a lower Basic Insulation Level (BIL) and protection level against lightning.

## **E.1.2 Uprating underground cables**

### **Maximum cable temperature**

The ampacity of a cable system is limited by the maximum allowable insulation temperature (normally at the interface between conductor and insulation) or the maximum outer sheath temperature in relation to the dry-out temperature of the surrounding soil. In a similar way to OHL, if there is enough distinction between the temperatures during the year this can be used for a temporary uprating during part of the year.

**Dynamic loading**

This is the most common way to increase the power capacity (indicative 10 to 50%). Cables have a high thermal capacity due to the cable materials, but this is even greater for directly buried cables due to their environment. This means that as the load is increased the cable temperature will rise very slowly (thermal inertia). This phenomenon can be used to allow a short-term rating higher than the continuous rating. See Appendix B3.2 for further details.

**Real time monitoring and thermal rating**

By measuring the conductor or sheath temperature and the temperature of the cable environment it is possible to determine the ampacity and for the next time period. This is only useful for short-term operations.

**Voltage uprating**

Voltage uprating mainly consists of exchanging the cable for one of a higher voltage range at places where digging is not necessary, e.g. where it is installed in pipes, ducts or tunnels. In such installations, it is sometimes an option to install more cables per phase or cables with a greater cross section at the same voltage level.

**Cross bonding instead of solid bonding**

A solidly bonded cable systems can be uprated by converting it to a cross bonding system. This is only applicable to single core cable systems with insulated outer sheaths. It is most effective for cables installed in flat formation. For further details on bonding systems see Appendix C.

**Removing bottlenecks**

The ratings of cable circuits are sometimes limited by a few places where thermal conditions are worse than the rest. Removing these bottlenecks is possible by the use of special back-fill sand (low thermal resistance) or bentonite in the case of horizontal drilling, increasing the spacing between the cables or the local use of a cable with a greater conductor cross section.

**Indirect cooling of the cable surface**

By adding cooling pipes it is possible to carry away the heat produced by the cable system. This method can be used locally to solve a bottle neck, mainly at places where many cable meet each other or over the full length. The last is economically less attractive due to the cost of civil works.

## ***E.2 Monitoring***

To ensure safe operation and to check the condition of the insulation some cables are fitted with monitoring systems. The type of monitoring systems mainly depends on the type of cable and particularly the nature of the insulation systems.

For many years the pressure in oil-filled and gas pressure cables has been monitored. For oil-filled cables with insulation consisting of oil and lapped paper, it is necessary to ensure that the insulation is completely filled with oil in order to eliminate any voids. For gas pressure cables with insulation consisting of gas and impregnated papers, it is necessary to ensure that the pressure is high enough to suppress ionisation.

Distributed temperature monitoring is increasingly being used to increase the transmission capacity of cable systems [27].

For modern XLPE cable systems the condition of the insulation can be monitored by detecting partial discharge (PD) activity. Monitoring systems currently in use tend to concentrate on PD in the vicinity of joints and terminations. The PD sensor itself is usually fairly simple but the detection and evaluation of the signals is very complex.

Monitoring of the PD in XLPE cable systems can improve their reliability by giving early warning of electrical degradation.

### **E.2.1 Oil Pressure measurements**

It is very important that the oil pressure in oil-filled cables is monitored. Pressure tanks are installed, mainly at the terminations (sealing ends) but also in separate hydraulic sections along the routes, for long land cables, in order to maintain an over-pressure to ensure that no voids occur in the insulation. Oil pressures in the cables and oil tank levels normally vary with the cable temperature due to thermal expansion of the oil. Pressure gauges are installed fitted with low pressure alarm contacts initiating remote indications of abnormally low pressure. By checking the gauge readings it can be assured that the sheath is intact and consequently the insulation system is not damaged.

### **E.2.2 Gas Pressure measurements**

For gas pressure cables it is necessary that the pressure is monitored. The gas pressure is maintained through cubicles located at the cable ends. The cubicle contains typically two or three cylinders of nitrogen connected into a manifold. The gas is fed into the cable at the sealing ends or into the joint of a three core cable. The gas feed is controlled by a two-stage regulator and the pressure is monitored by pressure gauges which are equipped with electrical alarm contacts initiating remote indications if the gas pressure falls below a specified limit.

### **E.2.3 Temperature measurements**

The simplest way to provide temperature measurements is by use of discrete sensors such as thermocouples which can be placed in the ground and on cable sheath at specific points. It needs only basic instruments to record the results.

More comprehensive measurements can be done by use of a distributed temperature sensing (DTS) system where an optical fibre cable is used to continuously monitor the temperature profile along the cable route.

DTS systems basically utilize the losses in optical fibres for the measurement of temperature. A small proportion of the light transmitted through a fibre is scattered back along the fibre. This back-scattered light can be analysed to measure the temperature of the fibre.

Double ended measurements (measurements from both ends of a loop of fibre) allow higher precision and, in case of a fibre break, the possibility to continue measuring in a single ended manner on the remaining fibre.

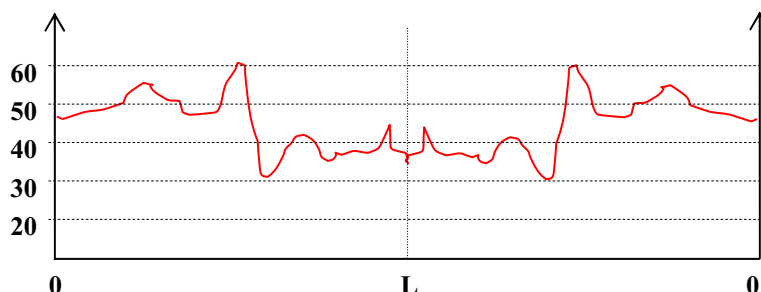

Figure E.1: Double-ended temperature monitoring. The temperature profile is symmetrical about the centre of the fibre loop.

As an example of the sensitivity of commercially available systems, the following data refers to the Sensa DTS 800 'M' and 'S' series:

Multi-mode fibres can handle double-ended temperature measurements for a fibre loop length up to 12 km with high accuracy and spatial resolution, e.g.  $\pm 1$  °C and 1 - 2 m.

Single mode fibres can handle single-ended temperature measurements for a fibre length of approximate 15-30 km but with a lower accuracy and spatial resolution, e.g.,  $\pm 2$  °C and 10 m.

The monitoring fibre can be integrated into the cable's copper wire screen. This solution gives the most sensitive measurement when single core cables are installed separately. In this case a fibre in metallic tube (FIMT) may be used to replace one copper wire in the cable screen.

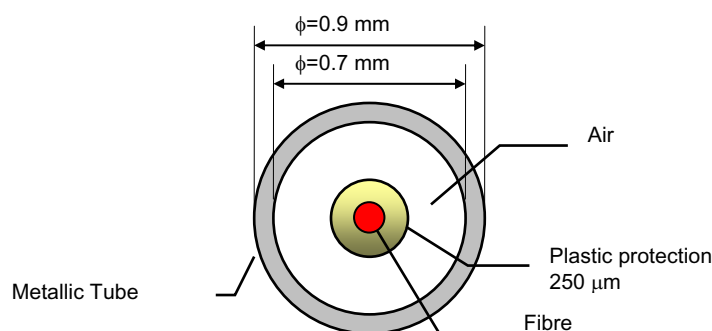

Figure E.2: An example of a FIMT (Fibre in Metallic Tube)

For cable installed in trefoil formation the most sensitive monitoring is achieved by installing an optical fibre cable in the centre of the trefoil.

If the DTS system is being used to infer the conductor temperature by measuring the screen temperature the accuracy of the measurement is only slightly reduced if the fibre is placed just outside the sheath in a small PVC tube or even better in a metallic tube. In this case there is an

opportunity to change the fibre in the future and also longer fibre lengths can be installed without joints.

#### **E.2.4 Partial Discharge Measurements**

Partial discharge can be used as an indicator of aged or damaged insulation, before a breakdown occurs. Sensors are designed to detect either the electric displacement field (for a capacitive field sensor) or the magnetic field of the transient PD current (for an inductive sensor). The inductive field coupling is usually done with a high-frequency current transformer or a magnetic field antenna, but the latter is not really suitable for use in cable systems.

PD measurement with a capacitive sensor picks up the electric field energy of the PD pulses with a metallic electrode structure or additional metallic foil layers placed in the electric field. This is mostly realized as a dual capacitive sensor working in differential mode to discriminate PD from external noise.

For cable system accessories the partial discharge level can be measured by capacitive signal coupling. The stress relief cone in the joint or the termination can act as an electrode for measurement of PD.

Measurements on-site are often affected by electromagnetic noise. Therefore powerful noise suppression is necessary. The expected partial discharge detection sensitivity varies widely from a few pC to 50 pC or even more, depending on the presence and severity of external noise sources at the location of the cable route.

The PD signal is evaluated by decoupled signals from the sensors and is evaluated in a data acquisition unit. Considering a known model of PD phenomena the analysis and diagnosis can be carried out in an expert system. Consequently there are two output requirements. The basic one is a continuous data logger to record the full PD history. The other important demand is an alarm output.

Evaluating the PD signal is very complex and demands experience in order to judge the recorded signals. In the future we can expect instruments to have more sophisticated learning and analysis systems, which could trigger autonomously a service or maintenance action before a fault happens.

## Appendix F COST ESTIMATION

### *F.1 Components of cost for underground cable systems*

In order to estimate the costs of an underground cable system it is convenient to break these down into the costs incurred during the various stages of the cable's lifecycle:

- Planning/Design
- Procurement
- Construction
- Operation
- End of Life

Each stage of the life can be subdivided further and the costs estimated. These more detailed headings are specific to the individual circumstances of each job. For example, if a cable were to be installed in tunnel, the construction costs could include:

- build the tunnel
- install the ventilation system
- install supporting steelwork for the cable
- pull in the cable
- joint the cable

Assuming that the need for a circuit has been identified and hence basic design parameters (kV, MVA, time scale etc) are available, it is then possible to make an estimate of the likely cost

Broad headings for guidance are given below:

#### **PLANNING/DESIGN**

Route selection

Environmental impact assessment

Obtaining consent (this may include the cost of any delay)

#### **PROCUREMENT**

Buy land or the right to access in order to build, maintain and repair the cable

Develop purchase and testing specifications

Procurement costs

Prequalification & type testing costs

Purchase cable system (including accessories, bonding system etc)

Purchase monitoring and ancillary systems

Purchase Reactive compensation

Purchase protection/reclosure equipment

## **CONSTRUCTION**

Removal/relocation/undergrounding of other (often lower voltage) circuits

Relocation of other services e.g. water, telecommunications and gas

Trenching and ducting civil costs

Civil engineering costs at cable ends

Install cable

Fit joints and terminations

Install ancillary equipment (e.g. protection, alarms, monitoring, etc.)

Cost of tests after installation

Cost of protecting the public from the cable (e.g. in the event of a fault)

Cost of protecting the cable from the public

Cost of protecting the environment during construction

Cost of other mitigation measures

Cost of reinstatement

Advanced costs of any future expansion/upgrading

## **OPERATION**

Compensation for restricting land use and other on-going land costs

Likely cost of future expansion/upgrading

Cost of maintenance

Cost of planned outage for maintenance

Cost of spares holdings

Cost of losses

Cost of repair

Cost of outage for repair



**END OF LIFE**

Dig up and recover cable

Disposal costs minus scrap value

***F.2 Components of cost for overhead line systems***

In the same way as underground cables, it is possible to subdivide the costs of building an overhead line into various stages:

- Planning/Design
- Procurement
- Construction
- Operation
- End of life

In contrast with cables, the distribution of the costs between supply and installation is completely disproportionate. Indeed the supplies (insulators, fittings, etc) represent only a few percent of the total budget, the main activity being the installation (with possible major costs of civil works according to the type of soil).

**PLANNING/DESIGN**

Route selection and line design in view of visual impact

Environmental impact assessment

Obtaining consent (this may include the cost of any delay)

Tests to acquire knowledge of soil and terrain conditions as well as access to the individual tower sites for selecting the type of foundation

**PROCUREMENT**

Buy land (location of the towers) or the right to access in order to build, maintain and repair the line

Develop purchase and testing specifications

Procurement costs

Prequalification and type testing costs

Purchase insulators, fittings, conductors, towers

Purchase ancillary equipment (spacers, warning spheres, night warning devices, etc)

Purchase monitoring equipment  
Purchase protection/reclosure equipment

### **CONSTRUCTION**

Foundations (separate footing foundations, bored piles, etc)  
Assembly and erection of towers  
Install insulator sets (suspension string, tension strings) and hardware  
Install conductors  
Install ancillary equipment (e.g. spacers, warning spheres, night warning device, real time monitoring, GSM antennas)  
Cost of tests after installation (earthing resistance)  
Cost of protecting the environment during construction  
Cost of other mitigation measures  
Cost of reinstatement  
Advanced costs of any future uprating/upgrading/refurbishment

### **OPERATION**

Compensation for restricting land use and other on-going land costs  
Likely cost of future uprating/upgrading/refurbishment  
Cost of maintenance  
Cost of planned outage for maintenance  
Cost of losses  
Cost of repair  
Cost of outage for repair

### **END OF LIFE**

Remove towers and above-ground equipment  
Disposal costs minus scrap value

## APPENDIX G: SIGNIFICANT CABLE PROJECTS

Table G1: Overview of significant underground cable projects constructed since 1996. Projects are arranged in order of decreasing voltage and conductor size

Country	Project name	Voltage		Conductor		Insulation material	Number of Circuits	Route length		Installation	Date
		kV	mm <sup>2</sup>	mm <sup>2</sup>	material			km	km		
Japan	Shinkeiyo-Toyosu	500	2500	Cu	XLPE	Double	39.8		Tunnel, Bridge	2000	
Spain	Barajas Airport	400	2500	Cu	XLPE	Double	12.8		Tunnel	2004	
UK	Elstree-St Johns Wood	400	2500	Cu	XLPE	Single	20		Tunnel	2005	
UK	Nunthorpe-Newby	400	2000	Cu	PPL/DBB	Double	5.7		Direct buried	2004	
Denmark	Metropolitan Power Project	400	1600	Cu	XLPE	Single	12.0, 9.0		Direct buried	1997	
Denmark	Metropolitan Power Project	400	1600	Cu	XLPE	Single	12.0		Direct buried	1999	
Denmark	Aarhus-Aalborg	400	1200	Al	XLPE	Single	2.5, 4.5 & 7.5		Direct buried or duct	2004	
Italy	Turbigo-Rho	380	2000	Cu	XLPE	Double	8.4		Direct buried		
Germany	Berlin Diagonal	380	1600	CU	XLPE	Double	6.3 and 5.2		Tunnel	1998/2000	
Netherlands	Nieuwe Waterweg and Calandkanaal crossing	380	1600	Cu	XLPE	Double	2.25		Direct buried or duct	2005	
Austria	Wienstrom	380	1200	Cu	XLPE	Double	5.2		Direct buried & tunnels	2005	
Germany	Goldisthal Pumped Storage	380	630	CU	XLPE	Four	0.4		Tunnel	2002	
Korea	Sinbupoung-Seoinchon	345	2000	Cu	PPL	Three	17		Tunnel	2002	
Korea	Nampusan-Bukpusan	345	2000	Cu	PPL	Single	22		Tunnel	1998	
Korea	Nampusan-Bukpusan	345	2000	Cu	PPL	Single	22		Tunnel	1998	
Korea	Nampusan-Bukpusan	345	2000	Cu	PPL	Single	22		Tunnel	2003	
Korea	Mikeum-Soungdong	345	2000	Cu	PPL	Single	16.7		Tunnel	1997	
Korea	Mikeum-Soungdong	345	2000	Cu	PPL	Single	16.7		Tunnel	1997	
Korea	Mikeum-Soungdong	345	2000	Cu	PPL	Single	16.7		Tunnel	2002	
Korea	Shinyangjai-Shinsoungnam	345	2000	Cu	PPL	Double	9		Tunnel	2001	
Korea	Shinyangjai-Shinsoungnam	345	2000	Cu	PPL	Double	9		Tunnel	2001	
Korea	Youngseo-Youngdeungpo	345	2000	Cu	XLPE	Double	9.8		Tunnel	2003	
USA	Bethel to Norwalk	345/115		Cu	HPFF/XLPE				Ducts, direct buried	2006	

Country	Project name	Voltage		Conductor		Insulation material	Number of Circuits	Route length		Installation	Date
		kV	mm <sup>2</sup>	mm <sup>2</sup>	material			km	km		
Australia	Sydney South to Sydney Central	330	1600	Cu	PPL/DBB	Single	28		Direct buried, ducts, tunnel	2004	
Japan	Shinmeika-Tokai	275	9400	Al	GIL	Double	3.3		Tunnel	1998	
Japan	Kawagoe-Nishinagoya	275	2500	Cu	XLPE	Double	14.4		Tunnel	2002	
USA	Jefferson - Martin	230	1267	Cu	XLPE	Single	19 & 19		Ducts, direct buried	2006	
France	Biançon - Mougins	225	1600	Cu	XLPE	Single	8.3		Duct bank, trough and tunnel	2002	
France	Biançon - Plan de Grasse	225	1600	Cu	XLPE	Single	7.4		Duct bank, trough and tunnel	2002	
France	Antibes - Mougins	225	1200	Cu	HDPE	Double	11.3		Duct bank	1997	
France	Nîmes - Talabot	225	1200	Cu	XLPE	Single	4.6		Duct bank, trough and tunnel	2001	
France	Avenir - Sausset	225	1200	Cu	XLPE	Single	17.9		Duct bank, trough and tunnel	2001	
France	Mouguerre - Tarnos	225	1000	Al	HDPE	Single	9.4		Duct bank and trough	1996	
Mexico	Agua Azul - Alamo	225	1000	Cu	XLPE	Double	5		Duct	2002	
Tunisia	Rades - Grombalia 2	225	1000	Cu	XLPE	Single	24.7		Duct	2005	
France	Pont 7 - Sainneville	225	800	Al	XLPE	Single	4.4		Duct bank and trough	2002	
Oman	Sohar	220	2500	Cu	XLPE	Single	3.3		Direct buried	2005	
Ireland	Shellybanks	220	1600	Cu	XLPE	Single	14		Direct buried, river crossing	1997	
Italy	Piofello	220	1600	Al	XLPE	Double	3+3		Direct buried	2005	
Vietnam	Tao Dan	220	1600	Cu	XLPE	Double	6.2		Direct buried	2002	
Germany	Lubeck - Siemens	220	1200	CU	XLPE	Double	10.2		Pipes, direct buried	2004	
Sweden	Bergshamra	220	1200	Al	XLPE	Single/Double	10.3		Tunnel	1998	
Belgium	Koksijde - Sijjkens	150	2000	Al	XLPE	Single	30		Direct buried	2006	
Belgium	Tihange - Averages	150	2000	Al	XLPE	Double	30		Direct buried	2005	
Denmark	Karlsgårde-Blåvand	150	1200	AL	XLPE	Single	35.0		Direct buried	2001	
Denmark	Tinghøj - Haverslev	150	1200	AL	XLPE	Single	21.0		Direct buried	2000	
Denmark	Mesballe-Aastrup	150	800	Al	XLPE	Single	27.6		Direct buried or duct	2000	
Denmark	Trige-Aastrup	150	800	Al	XLPE	Single	27.7		Direct buried or duct	2000	
Italy & France	SARCO	150	400	Cu	XLPE	Single	5 & 11		Direct buried		

Country	Project name	Voltage		Conductor		Insulation material	Number of Circuits	Route length		Installation	Date
		kV		mm <sup>2</sup>	material			km			
Denmark	Radsted - Vantore Str.	132		1200	Al	XLPE	Single	18.0		Direct buried + ducts	2002
Sri Lanka	CEB	132		1000	Cu	XLPE	Single	11.5		Ducts, direct buried	2006
Sri Lanka	CEB	132		800	Cu	XLPE	Single	14.5		Ducts, direct buried	2006
Denmark	Radsted-Rødby	132		630	Al	XLPE	Single	25.0		Direct buried + ducts	1999
New Zealand	Penrose-Liverpool	110		1000	Al	XLPE	Double	8.1		Tunnel	1999
New Zealand	Roskill-Liverpool	110		1000	Al	XLPE	Single	9		Direct buried	1998
France	Locmalo-Plouay	63		800	Al	XLPE		19		Ducts in soil	
France	Chabossière - Montluc	63		400	Al	XLPE	Single	10.1		Duct bank	2003

**Table G2: Overview of significant underground cable projects constructed since 1996. Projects are arranged in order of country and geographical location**

Country	Location	Project name	Voltage kV	Conductor		Insulation material	route length		Installation	Date
				mm <sup>2</sup>	material		km	km		
Australia	Sydney	Sydney South to Sydney Central	330	1600	Cu	PPL/DBB	28		Direct buried, ducts, tunnel	2004
Austria	Wienstrom		380	1200	Cu	XLPE	5.2		Direct buried & tunnels	2005
Belgium	Belgian coast	Koksijde - Slijkens	150	2000	Al	XLPE	30		Direct buried	2006
Belgium	East of Brussels	Tihange - Avernoas	150	2000	Al	XLPE	30		Direct buried	2005
Denmark	Copenhagen	Metropolitan Power Project	400	1600	Cu	XLPE	12.0, 9.0		Direct buried	1997
Denmark	Copenhagen	Metropolitan Power Project	400	1600	Cu	XLPE	12.0		Direct buried	1999
Denmark	Jutland	Aarhus-Aalborg	400	1200	Al	XLPE	2.5, 4.5 & 7.5		Direct buried or duct	2004
Denmark	Jutland	Karlsårde-Biåvand	150	1200	Al	XLPE	35.0		Direct buried	2001
Denmark	Jutland	Mesballe-Aastrup	150	800	Al	XLPE	27.6		Direct buried or duct	2000
Denmark	Jutland	Tinghøj - Haverslev	150	1200	Al	XLPE	21.0		Direct buried	
Denmark	Jutland	Trige-Aastrup	150	800	Al	XLPE	27.7		Direct buried or duct	2000
Denmark	Lolland	Radsted - Vantore Str.	132	1200	Al	XLPE	18.0		Direct buried + ducts	2002
Denmark	Lolland	Radsted-Rødby	132	630	Al	XLPE	25.0		Direct buried + ducts	1999
France	Alpes-Maritimes	Antibes - Mougins	225	1200	Cu	HDPE	11.3		Duct bank	1997
France	Alpes-Maritimes	Biançon - Mougins	225	1600	Cu	XLPE	8.3		Duct bank, trough and tunnel	2002
France	Alpes-Maritimes	Biançon - Plan de Grasse	225	1600	Cu	XLPE	7.4		Duct bank, trough and tunnel	2002
France	Brittany	Locmalo-Plouay	63	800	Al	XLPE	19		Ducts in soil	
France	Gard	Nîmes - Talabot	225	1200	Cu	XLPE	4.6		Duct bank, trough and tunnel	2001
France	Ile de France	Avenir - Sausset	225	1200	Cu	XLPE	17.9		Duct bank, trough and tunnel	2001
France	Loire-Atlantique	Chabossière - Montluc	63	400	Al	XLPE	10.1		Duct bank	2003
France	Pyénées-Atlantiques	Mouguerre - Tarnos	225	1000	Al	HDPE	9.4		Duct bank and trough	1996
France	Seine-Maritime	Pont 7 - Sainneville	225	800	Al	XLPE	4.4		Duct bank and trough	2002

Country	Location	Project name	Voltage		Conductor		Insulation		route length		Installation	Date
			kV	mm <sup>2</sup>	material	material	km	km				
Germany	Berlin	Berlin Diagonal	380	1600	Cu	XLPE	6.3 and 5.2	Tunnel	1998 / 2000			
Germany	Schleswig-Holstein	Lubeck - Siems	220	1200	Cu	XLPE	10.2	Pipes, direct buried	2004			
Germany		Goldisthal Pumped Storage	380	630	Cu	XLPE	0.4	Tunnel	2002			
Ireland	Dublin	Shellybanks	220	1600	Cu	XLPE	14	Direct buried, river crossing	1997			
Italy	Milan	Piofello	220	1600	Al	XLPE	3+3	Direct buried	2005			
Italy	Milan	Turbigo-Rho	380	2000	Cu	XLPE	8.4	Direct buried				
Italy & France	Sardinia-Corsica	SARCO	150	400	Cu	XLPE	5 & 11	Direct buried				
Japan	Chubu	Kawagoe-Nishinagoya	275	2500	Cu	XLPE	14.4	Tunnel	2002			
Japan	Chubu	Shinmeika-Tokai	275	9400	Al	GIL	3.3	Tunnel	1998			
Japan	Tokyo	Shinkeiyo-Toyosu	500	2500	Cu	XLPE	39.8	Tunnel, Bridge	2000			
Korea	Inchon	Sinbupoung-Seoinchon	345	2000	Cu	PPL	17	Tunnel	2002			
Korea	Pusan	Nampusan-Bukpusan	345	2000	Cu	PPL	22	Tunnel	1998			
Korea	Pusan	Nampusan-Bukpusan	345	2000	Cu	PPL	22	Tunnel	1998			
Korea	Pusan	Nampusan-Bukpusan	345	2000	Cu	PPL	22	Tunnel	2003			
Korea	Seoul	Mikeum-Soungdong	345	2000	Cu	PPL	16.7	Tunnel	1997			
Korea	Seoul	Mikeum-Soungdong	345	2000	Cu	PPL	16.7	Tunnel	1997			
Korea	Seoul	Mikeum-Soungdong	345	2000	Cu	PPL	16.7	Tunnel	2002			
Korea	Seoul	Shinyangjai-Shinsoungnam	345	2000	Cu	PPL	9	Tunnel	2001			
Korea	Seoul	Shinyangjai-Shinsoungnam	345	2000	Cu	PPL	9	Tunnel	2001			
Korea	Seoul	Youngseo-Youngdeungpo	345	2000	Cu	XLPE	9.8	Tunnel	2003			
Mexico	Guadalajara	Agua Azul - Alamo	225	1000	Cu	XLPE	5	Duct	2002			
Netherlands	Rotterdam	Nieuwe Waterweg and Calandkanaal crossing	380	1600	Cu	XLPE	2.25	Direct buried or duct	2005			
New Zealand	Auckland	Penrose-Liverpool	110	1000	Al	XLPE	8.1	Tunnel	1999			
New Zealand	Auckland	Roskill-Liverpool	110	1000	Al	XLPE	9	Direct buried	1998			
Oman	Sohar	Sohar	220	2500	Cu	XLPE	3.3	Direct buried	2005			

Country	Location	Project name	Voltage		Conductor		Insulation		route length		Installation	Date
			kV	mm <sup>2</sup>	material	material	material	km				
Spain	Madrid	Barajas Airport	400	2500	Cu	XLPE	XLPE	12.8	Tunnel		2004	
Sri Lanka	Colombo	CEB	132	1000	Cu	XLPE	XLPE	11.5	Ducts, direct buried		2006	
Sri Lanka	Colombo	CEB	132	800	Cu	XLPE	XLPE	14.5	Ducts, direct buried		2006	
Sweden	Stockholm	Bergshamra	220	1200	Al	XLPE	XLPE	10.3	Tunnel		1998	
Tunisia	Tunis	Rades - Grombalia 2	225	1000	Cu	XLPE	XLPE	24.7	Duct		2005	
UK	London	Elstree-St Johns Wood	400	2500	Cu	XLPE	XLPE	20	Tunnel		2005	
UK	Teesside	Nunthorpe-Newby	400	2000	Cu	PPL/DDB	PPL/DDB	5.7	Direct buried		2004	
USA	New England	Bethel to Norwalk	345/115		Cu	HPFFXLPE	HPFFXLPE		Ducts, direct buried		2006	
USA	San Francisco	Jefferson - Martin	230	1267	Cu	XLPE	XLPE	19 & 19	Ducts, direct buried		2006	
Vietnam	HoChiMinh City	Tao Dan	220	1600	Cu	XLPE	XLPE	6.2	Direct buried		2002	



**Table G3: Index to brief project descriptions**

Index	Country	Project name	Voltage		Conductor		Insulation		Installation	Hybrid cable & OHL route	Date
			kV	(mm <sup>2</sup> )	material	material	material				
SP 01	Denmark	Aarhus-Aalborg	400	1200	Al	XLPE			Direct buried or duct	Yes	2004
SP 02	UK	Nunthorpe-Newby	400	2000	Cu	PPL/DDB			Direct buried	Yes	2004
SP 03	France	Locmalo-Plouay	63	800	Al	XLPE			Ducts in soil	No	
SP 04	Italy	Turbigo-Rho	380	2000	Cu	XLPE			Direct buried	Yes	
SP 05	Netherlands	Nieuwe Waterweg & Calandkanaal	380	1600	Cu	XLPE			Direct buried or duct	Yes	2005
SP 06	Belgium	Tihange - Avernas	150	2000	Al	XLPE			Direct buried	Yes	2003
SP 07	Denmark	Metropolitan Power Project	400	1600	Cu	XLPE			Direct buried	No	1997
SP 07	Denmark	Metropolitan Power Project	400	1600	Cu	XLPE			Direct buried	yes	1999
SP 08	Austria	Wienstrom	380	1200	Cu	XLPE			Direct buried & tunnels	Yes	2005
SP 09	Korea	Youngseo-Youngdeungpo	345	2000	Cu	XLPE			Tunnel	No	2003
SP 09	Korea	Youngseo-Youngdeungpo	345	2000	Cu	XLPE			Tunnel	No	2003
SP 10	Germany	Lubeck - Siemens	220	1200	CU	XLPE			Pipes, direct buried	No	2004
SP 11	Germany	Berlin Diagonal	380	1600	CU	XLPE			Tunnel	No	1998 / 2000
SP 12	Germany	Goldisthal Pumped Storage	380	630	CU	XLPE			Tunnel	No	2002
SP 13	Japan	Shinkeiyo-Toyosu	500	2500	Cu	XLPE			Tunnel, Bridge	No	2000
SP 14	Japan	Kawagoe-Nishinagoya	275	2500	Cu	XLPE			Tunnel	No	2002
SP 15	Japan	Shinmeika-Tokai	275	9400	Al	GIL			Tunnel	No	1998
SP 16	Belgium	Koksijde - Slijkens	150	2000	Al	XLPE			Direct buried	No	2006
SP 17	Italy	Pioltello	220	1600	Al	XLPE			Direct buried	Yes	2005
SP 18	Spain	Barajas Airport	400	2500	Cu	XLPE			Tunnel	Yes	2004
SP 19	France	Chabossière - Montluc	63	400	Al	XLPE			Duct bank		2003
SP 20	Italy/ France	SARCO	150	400	Cu	XLPE			Direct buried	No	
SP 21	USA	Bethel to Norwalk	345/115		Cu	HPFF/XLPE			Ducts, direct buried	Yes	2006
SP 22	USA	Jefferson - Martin	230	1267	Cu	XLPE			Ducts, direct buried	Yes	2006
SP 23	Tunisia	Rades - Grombalia 2	225	1000	Cu	XLPE			Duct		2005

## SP 01: Underground cables in the Aarhus-Aalborg 400 kV transmission line (Denmark)

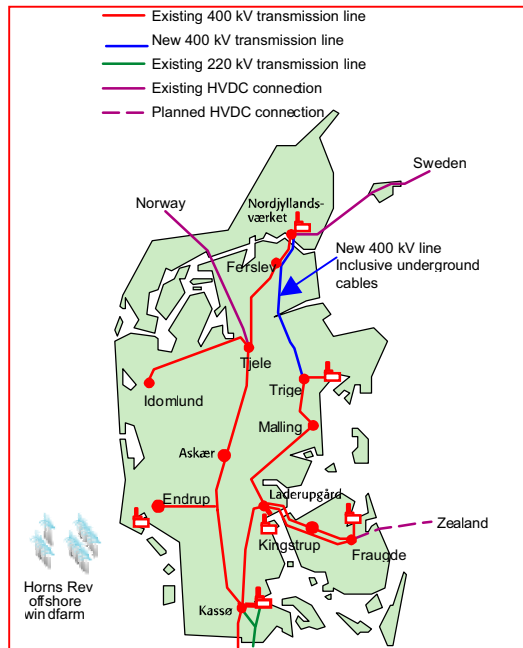

### Overview

In 2004, three extruded 400 kV double cable circuits were commissioned in the transmission grid in Denmark. The three double circuits are made as siphons for an overall route length of 14.7 km in a new 400 kV line from Aarhus to Aalborg (140 km). It was a political decision to build part of the line with underground cables.

### Circuit details

For the first time part of a 400 kV line was undergrounded in the open countryside in a very simple way. The three siphons were built on grounds of nature. The first siphon is 4.5 km long and crosses a valley with a river (Gudenaen). The next is 2.8 km long and crosses a fjord (Mariager Fjord). The third is 7.4 km long and goes along a valley (Indkildedalen).

### Technical details

The three cables in each circuit are laid in flat formation with a distance between the phases equal to 300 mm.

The distance between the two circuits is 6 m.

Crossing of rivers, streams, roads and other cables or pipes are made by directional drilling or by buried pipes. Crossing of a 700 m wide fjord is done by pulling the cables through ducts previously lowered to the sea bottom.

The 400 kV cables generate about 10 Mvar per circuit km. This means a total generation of  $2 * 14.7 \text{ km} * 10 \text{ Mvar/km} = 295 \text{ Mvar}$ .

The generation is compensated mainly in two reactors (100 and 140 Mvar), which are directly linked to the line itself. A third reactor (70 Mvar) can be switched on and off.

The nominal rating of the cables is  $2 * 825 \text{ A}$ . Because of deep drillings the actual possible continuous load is only 700-750 A, when we demand a maximum temperature of the outer surface of only 50 °C to prevent from thermal run-away.

If the continuous rating is 700 A per circuit, the total rating will be 1400 A (1000 MVA). The overhead line connected to the underground cables has a nominal rating equal to 2000 MVA per circuit. Under conservative considerations the cable transmission capacity is only half of the overhead line's capacity.

Because of the large thermal time constant in the cable surroundings it is possible to load the cables harder for some hours without overloading them. In the project it was calculated that when the total preload was equal to 500 MVA it would be possible to load the double cable systems up to 2000 MVA for almost 30 hours without having the conductor temperature raised to more than 90 °C.



## SP02: A high capacity 400 kV transmission cable between Nunthorpe and Newby (UK)

### Overview

National Grid, as owner and operator of the high voltage transmission system in England and Wales, is legally required to provide connections to new power stations and demand points wherever they are situated. Increasing demand for transmission capacity in the North East of England led National Grid to strengthen the 400 kV transmission system in Teesside and through the Vale of York. This required the building of a 75 km long double circuit transmission line from Lackenby on Teesside, via Picton, to Shipton in North Yorkshire.

In 1991 National Grid applied for consent to construct an overhead line. The proposal was the subject of lengthy public inquiries. In March 1998 after a number of alternative proposals and further hearings, National Grid had effectively gained consent for the overhead line with the exception of a 1.33 km section at Nunthorpe and a 4.5 km section near Newby, which were to be undergrounded.



View of cable swath towards Roseberry Topping

Since these two sections were only 1 km apart it was decided to underground all of the 5.7 km of route between Nunthorpe and Newby as a single section. This avoided the cost and visual impact of an additional two transition compounds.

The section of underground route passes through a Special Landscape Area, lying between the N. York Moors National Park and Middlesborough, a conurbation of 150,000 people. Undergrounding this section helped preserve panoramic views of local landmarks (Roseberry Topping and the Cleveland Hills).

### Circuit details

The cables are designed to carry a continuous current of 3490 A (2418 MVA) in winter and

2930 A (2030 MVA) in summer. This needed two cables per phase with 2000 mm<sup>2</sup> copper conductors and PPL insulation, impregnated with DDB cable oil. The cables have corrugated aluminium sheaths and polyethylene oversheaths.

The cables were mainly directly buried in four trenches, two either side of a temporary haul road. The cables are surrounded by cement-bound sand to guarantee their thermal environment. Over short sections of the route the cables are installed in 200 mm diameter directionally drilled ducts, for example under woodland to save felling trees and to preserve hedgerows. To maintain the required rating, the cables fan out from the trench to pass through ducts spaced 2 metres apart. Another section of the route had to pass under a busy road, close to a roundabout. To minimise disruption, the cables were installed in ducts accurately positioned using laser-guided auger boring.



Cable spacing increased as cables enter ducts

### Technical Details

The project required 12 parallel cables over the 5.7 km route and the construction corridor is up to 40m wide in places. Consequently, considerable care was necessary during design and construction to minimise the impact of the cables on the environment. During topsoil stripping on one section of the route, an Iron Age round house was

discovered, excavated and recorded by an archaeologist, in line with a mitigation strategy that was drawn up at the project planning stages. Other measures included the safeguarding of topsoil for later reinstatement and the use of dedicated and sealed enclosures to house the oil feeding tanks

It has been National Grid's policy not to reinstate hedgerows over the cable swath. This avoids the risk of the cables overheating. The carefully designed thermal environment around the cables can be disrupted by both root growth and by the removal of moisture from the backfill by roots. Recent developments in distributed temperature monitoring mean that it is now feasible to monitor the temperature of the cables. Around half of the twelve sections of hedgerow affected cable route have been replanted. DTS monitoring equipment has been installed, to record cable temperature. If, after a sufficient monitoring period, the replanted hedgerows are found not to pose a significant threat to the cable, then the remaining hedgerows may be reinstated.

## SP03: An innovative installation technique – Locmalo to Plouay (France)

### General situation

There was an old overhead line between two substations, 19 km long, which had to be rebuilt. The alternative solution of an underground 63 kV line was proposed because it seemed possible to choose a direct route crossing fields, which allows to reduce the delay of the construction and to maintain an acceptable cost for the project.

This alternative has been chosen, with all the local players during the specific consultation process, and it was decided to erect it as a turn key project.

### A turn key project

Turn key projects are not a common practice for RTE, which generally studies the general design of the links, and to ensure coordination between works, providing on one hand cables and accessories, and on the other hand civil works and installation (the list of qualified companies is previously established). Since 2002, turnkey projects have been launched, as experiments, in order to promote new technologies or methods and reduce the total cost of underground links.

The project included:

contacts with the owners of the land, to obtain their agreement on the layout of the link where it crossed private property,  
detailed studies: research into installations owned by other utilities which could cross or run along the future link, determining the thermal and electrical design,  
civil engineering works,  
installation,  
on-site sheath tests.

### Technical design

The underground line is:

63 kV, 19 km long
5 joints
Cable : 800 mm <sup>2</sup> Aluminium conductor, aluminium screen
48 optical fibres, laid in a separate duct
HDPE ducts, d=125 mm, directly buried in soil

With the following ampacity:

	Summer	Winter
Continuous	660 A	780 A
3 weeks	730 A	860 A
1 hour	915 A	1050 A

The innovative feature was the use of pushing-floating techniques, inspired by the installation of telecommunication cables in pre-lubricated polyethylene ducts (using pressurised water instead of compressed air).

In addition to the effects of gravity, the fluid injected into the ducts avoids the sticking effect caused by the electrostatic field (PE cable overshath on the PE duct) and friction heating.

Friction is considerably reduced. The floating effect (according to Archimedes' principle) is combined with a mechanical pushing effect (caterpillars at the duct entry point) and may be improved by a classical pulling shuttle head. The stresses on cables are greatly reduced. It should be possible to increase cable lengths between joints even on complex routes.



The results of this experiment are as follows:  
the number of joints was decreased, from 15 for a conventional installation technique, down to 5 for the total 19 km length of the link. Some sections are as long as 3,300 m.  
the cables were modified in order to produce such long sections: the aluminium screen was transversally welded and tests were carried out in order to qualify this specific feature.  
the duration of the cable pulling in ducts was decreased.

These results highlight an interesting alternative to conventional methods, and further studies are being considered to confirm whether the technique would be effective and economical on more complex cable routes.

## SP04: Turbigo – Rho 380 kV Transmission Line (Italy)

### Overview

The need to reinforce the congested 380 kV transmission grid in a very densely populated and industrialized area in the proximity of Milano (North Italy) required the construction of a new 28 km long single overhead line between the Turbigo Power Plant and the Rho station.

### Technical details

In order to make it possible to cross some villages and an area having important natural reserves and to obtain quick permission, the undergrounding of the last 8.4 km of the total 28 km long line was necessary. To fulfill the thermal power rating of the overhead line, it was necessary to install two underground 380 kV cables per phase having a 2000 mm<sup>2</sup> copper conductor.

The two cable circuits were directly buried in trench at a depth of 1.5 m, one circuit per trench with cables laid flat spaced 350 mm and a distance between trenches of 6 m, to provide a continuous rating of each circuit of 1600 A. Each circuit was composed of 12 cable spans and 4 cross bonding sections. Outdoor terminations were installed in the overhead/underground transition compound.

Continuous temperature monitoring with a DTS system and continuous partial discharge monitoring at joints was also applied.

Special magnetic field shielding has been provided where necessary for some part of the route in order to comply with Italian legal requirements.

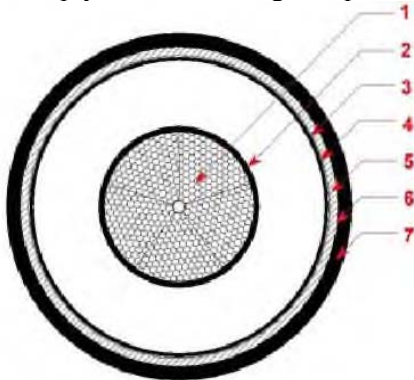

Figure 1 – 380 kV cable design  
 8- 2000 mm<sup>2</sup> copper conductor sealed  
 9- Semiconductor  
 10- XLPE insulation  
 11- Semiconductor  
 12- Waterblocking  
 13- Welded aluminium  
 14- PE outersheath



Figure 2: 380 kV cable joint bay

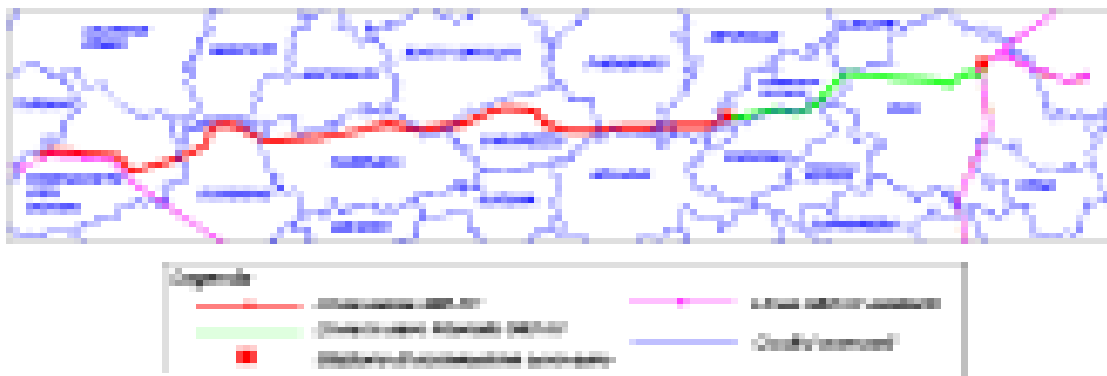

Figure 3: Turbigo Rho 400 kV connection layout

Reference: R. Rendina et al., “The new Turbigo-Rho 380 kV transmission line: an example of the use of underground XLPE cables in a meshed transmission grid” CIGRE 2006 paper B1-302

## SP05: An underwater 380 kV crossing in the Netherlands

### Overview

Part of the 380 kV grid reinforcement project in the Netherlands is to complete the double circuit loop in the province of Zuid-Holland. This meant crossing the river Nieuwe Waterweg and the adjacent Calandkanaal. Both waterways connect the Rotterdam harbours with the open sea. Between the Nieuwe Waterweg and the Calandkanaal there is a finger of land approximately 70 m wide.



Because the vertical clearance for the entry to Rotterdam harbour will be approximately 200 m, an overhead crossing of the waterways was not considered suitable. In that case three Eiffel towers in a row would have been constructed. So the grid owner decided to use a double circuit underwater crossing using horizontal directional drilling.

The cables will be joined into the existing 380 kV overhead line which is in operation at 150 kV. The capacity of the overhead line is 4000 A (2635 MVA). To match this continuous rating, three cables per phase would be necessary. The question

was to find a solution that is economically more attractive.

### Circuit details

The entire crossing of the two waterways is too long (approximately 1500 m) to cover with one directional drilling and the use of PE tubes. Therefore the drillings will have to be carried out in 2 stages; northwards from the finger of land across Nieuwe Waterweg (811 m) and southwards under the Calandkanaal (693 m). On the finger of land, joints will be placed and there will be a cable route in a trench connecting the two landing points of the drillings.

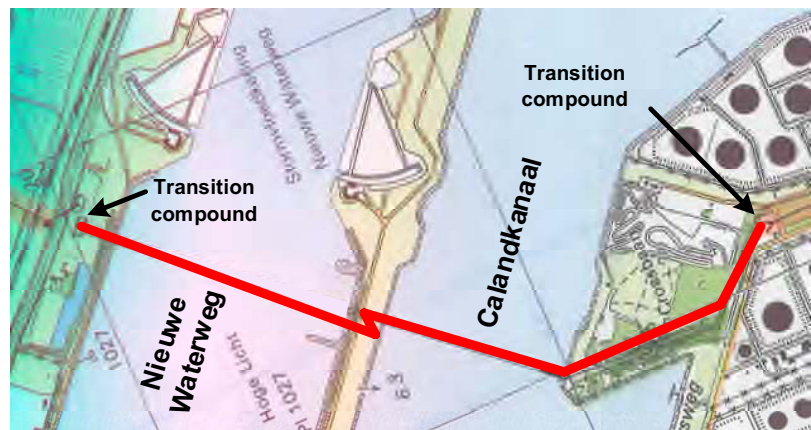

After careful evaluation of the possible solutions it was decided to install a forced water circulation system to equalize local hot spots in the directional drilling with cooler sections of the directional drilling. Normally the ground layer with the highest thermal resistance determines the necessary conductor size.

A small layer of ground with a high thermal resistance (1.05 Km/W) could have caused a hot-spot, but water circulation (without active heat exchanger) allowed the desired ratings with a copper conductor size of 1600 mm<sup>2</sup> rather than over 2500 mm<sup>2</sup>.

The land part of the cable connection (to the transition compounds on both banks), is approximately 700 m. The cable is direct buried in a trench, which is filled with a special back-fill material.



## Technical Details

The requirements for the final stage of the project are shown in Table 1. Introduction of an overload factor and carrying out the project in stages over a number of years (as the load grows) allows a more economical solution (Table 2).

Table 1: Final requirements

<b>Requirements final stage</b>			
Ampacity [A]	Rating [MVA]	Circuits in use	Duration
4000	2645	1	1 week
3250	2140	1	Repair time of side circuit
2500	1645	2	Continuous

Table 2. Staged requirements as the load grows.

<b>Project stages</b>					
Stage [year]	Voltage [kV]	Ampacity [MVA]	Load factor	Cable/phase	Remarks
-2005	150	280	1.0	1x 800 Cu 150 kV	Oil-filled cable from 1971
2005-2009	150	500	0.86	1x 1600 Cu 380 kV *	In operation under 150 kV
2009-200x	380	1000	1	1x 1600 Cu 380 kV *	Depends on load growth
200x-	380	1645	1	2x 1600 Cu 380 kV *	2635 MVA for one week

\* Include forced water circulation.

The forced water circulation system is an economically attractive solution because of the lower initial investment cost, even allowing for the higher joule losses, extra costs of maintenance and electricity for the pumps.

To meet the final requirements 2 cables per phase are required, but the second set can be postponed until necessary. Extra tubes for these cables are already installed in the first run.

To avoid extra joints (12 in the final state) and because it was not possible to create a balanced cross-bonding system, the system now has a single bonded earth system and two separate earth cables of 240 mm<sup>2</sup> Cu.

## SP06: The Tihange – Avernas 150 kV Link (Belgium)

### Overview

The connection between the Tihange nuclear power plant and the new transformer station in Avernas has marked a major enhancement to the grid in the region between Brussels and Liège (with the contribution of three other new links: Avernas – Tienen, two 21 km links and Avernas – Landen – Brustem, one 24 km link). It was also needed in order to provide power for the high-speed train running between Brussels and the German border. Featuring a high short-circuit power, the new transformer station was needed to prevent disrupting the power supply to other consumers.

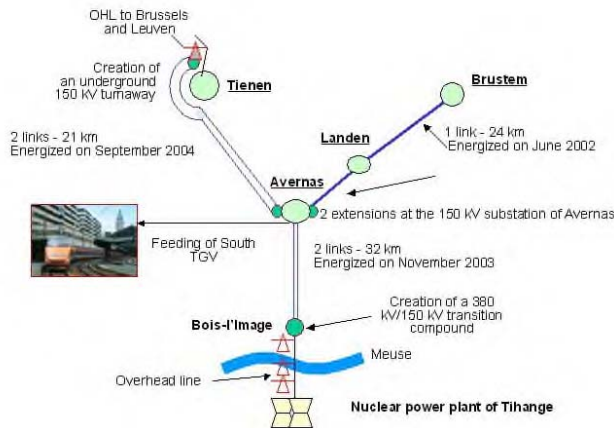

The initial project of a 380 kV overhead line between Tihange and Landen had been included in Belgium's 1985-1995 national development plan for power generation and transmission facilities, and the project was started accordingly in 1989. After a series of modifications, the federal government finally accepted in 1999 a mixed overhead-underground design for the link, which would start overhead for 4.5 km (380 kV) and would continue underground for some 27 km with a bundle of 150 kV cable. Due to the advice of the regional government and some opposition

from the public, the project was further modified and resulted in the present project: the exit from the nuclear power plant site and the crossing of the river Meuse where the plant is situated (2 km) is overhead and includes a new 380/150 kV substation; via a transition compound the remainder of the link is underground (30 km). The Tihange – Avernas project is one of the largest underground 150 kV connection projects in Europe. The project was launched in August 2002 and the official inauguration took place on 20 November 2003.

### Circuit details

Elia (Belgian Transmission System Operator) has imposed particularly stringent conditions on the carrying capacity, which resulted in considering a 150 kV underground link with 3 cables per phase, the third cable being installed only to face the situation in which one circuit failed. To avoid the cost of a third cable, a system with 2 cables per phase was finally chosen, based on a number of assumptions, one of these was the taking into account of a thermal resistivity value of 0.7 K.m/W for the controlled backfill (generalised in Belgium) instead of the usually adopted value of 1 K.m/W. The present underground connection consists thus of 2 parallel circuits composed of 2000 mm<sup>2</sup> aluminium XLPE cables (one of which incorporates optical fibres for tracing hot spots) laid in flat configuration. The cables are mainly directly buried in two trenches (also installed in ducts for the crossings of obstacles). In addition to the connection, there is also a telecommunication cable consisting of 48 optical fibres.



The use of cross-bonding makes it possible to suppress the circulating currents in the metallic screens that would otherwise reduce the ampacity of the link. The direct cross-bonding technique (without Screen Voltage Limiters) has been used systematically in Belgium on 150 kV underground links since 2000. Transposition of the phases is also performed at the same locations where the cross-bonding of the metallic screens is applied.

### Technical details

Overhead	Length: 2 km	2 sets of 2 conductors linked per phase	707 mm <sup>2</sup> AMS-2Z	Ampacity: 2 x 1161 A
Underground	Length: 30 km	2 parallel links in flat configuration	2000 mm <sup>2</sup> Alu XLPE	Ampacity: 2 x 1100 A with the possibility to have one link with 1900 A for one week

### Environmental concerns

Elia was especially conscious of the environmental ramifications of this project. For the underground connection, major efforts were made to restore the landscape after the work was completed. For instance, a disused railway line was converted into a path for hikers and cyclists. Aluminium screens were set up in some areas near dwellings and schools to reduce the magnetic field.

## SP07: 400 kV underground cables in Copenhagen (Denmark)

### Overview

In the early 1990s it was decided to renew the power supply to the Copenhagen area. The power supply consisted, among other lines, of several 132 kV overhead lines which were situated in densely populated areas. It was decided to remove these lines. To make this possible it was necessary to build two new 400 kV links and new 400 kV stations in the southern and northern part of the Copenhagen area. These new 400 kV links would, together with the Energy production from power stations in the Copenhagen area, give a secure power supply.

### Circuit details

The southern 400 kV link between the 400 kV station in Ishøj and a new 400 kV station at H. C. Oersted Vaerket has a total length of 21 km. This link consists of two cable systems with lengths of 12 and 9 km respectively. Between the two cable systems a 400 kV coupling station in Avedøre is constructed (for later connection to a new power station). The southern link was installed in the period from October 1995 to September 1997.

The northern link consists of a 7 km combined 132 and 400 kV overhead line and a 12 km 400 kV cable.

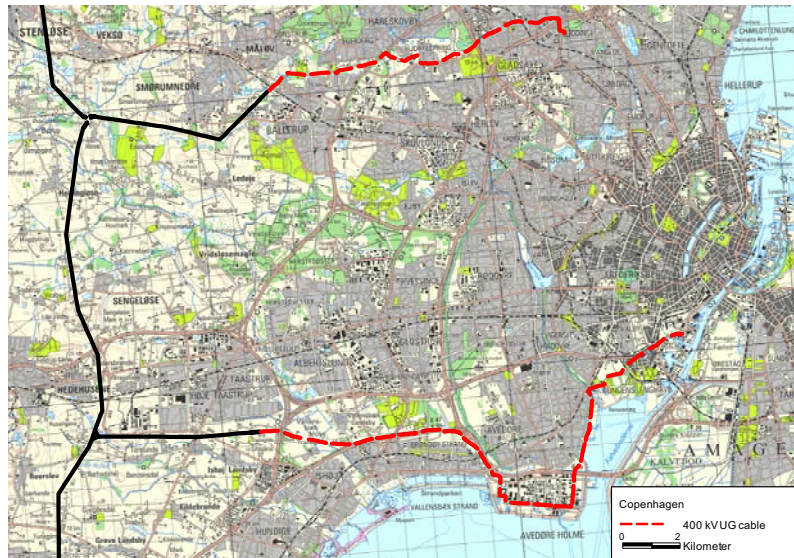

### Technical details

The 400 kV XLPE cables have  $1600 \text{ mm}^2$  Cu conductors. They are buried at a depth of 1.5 m.

In the southern link the 12 km long cable system is installed as 4 cross bonded major sections and three single bonded sections. The 9 km system is installed as 3 major cross bonded sections and 2 single bonded sections. The theoretical maximum transmission capacity of the system is 995 MVA, but the total system is designed for a transmission capacity of 975 MVA. A thermally stable backfill, weak concrete (weak-mix), has been used around the cables.

The installation of the cables is carried out in an open trench. The trench has a width of 1.1 m. At the bottom of the trench a layer of 20 cm concrete is placed. This layer will enable other lines to pass under the cable system in a later state and it gives a solid base for the equipment necessary for pulling in the cables. When the cable was placed on the concrete base a layer of 0.3 m of weak-mix was put over the cables. Normal soil was back filled into the trench and the top layer was re-established. This procedure has been used in a major part of the trenches.

Wherever use of an open trench was impossible either directional drilling or pipe jacking was used.

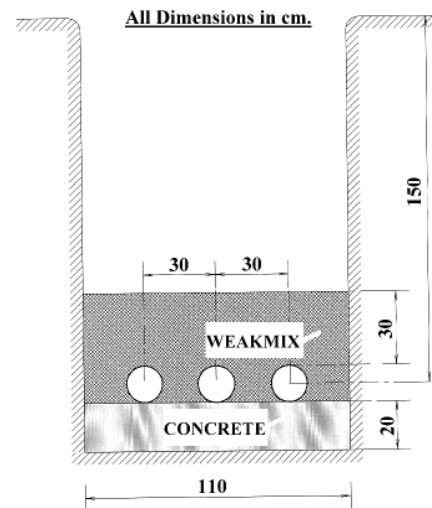

## SP08: 380 kV interconnection for Wienstrom (Austria)

To reinforce the supply system of the Austrian utility Wienstrom a new 380 kV interconnection from Bisamberg (Austrian Power Grid), located in the northern part of Vienna, to the northern substation of Wienstrom was started in 2004 and finished at the end of 2005. This 380 kV line has 2 sections. The first section with a length of 4.2 km is routed as an OHL with two circuits and the second section which leads through urban area is routed underground as a 380 kV XLPE cable (2 circuits) with a



length of 5.2 km. The cable is directly connected to the northern substation by means of the newly installed 380 kV GIS. The ampacity at a rated voltage of 380kV and natural cooling is 2 x 640 MVA, however, it can be increased to 2 x 1040 MVA by forced cooling through the jointly installed water pipes. The two cable circuits lead through city area and are situated 2.6 m below the pavement (both left and right of the street) in order to limit the magnetic field strength to 15  $\mu\text{T}$  at 1040 MVA. In the area of the joint bays additional magnetic shielding is set up. In order to cross under a water channel, which became necessary in the course of construction, the two circuits were laid 24 m below the ground in 2 tunnels of a length of 130 m each.

Table 1: Circuit parameters and technical details

Circuit parameters of the 380 kV interconnection WIENSTROM			
Ampacity: [MVA]/circuit natural cooled	Ampacity: [MVA]/circuit forced cooled	Route:	
		length: 5.2 km, 2 circuits	
620	1040	burial (pavement) depth: 2.6 m	2 tunnels length: 2 x 0.13 km depth: 24 m
Technical details (both circuits)			
380 kV XLPE Cable 1200 mm <sup>2</sup> miliken open trefoil laying, magn. field: 15 $\mu\text{T}$	10 joint bays with magnetic field. shielding (copper plates)	24 bonding joints	6 outdoor terminations
		6 straight joints	6 GIS terminations
		10 link boxes	2 temperature monitoring systems RTTR

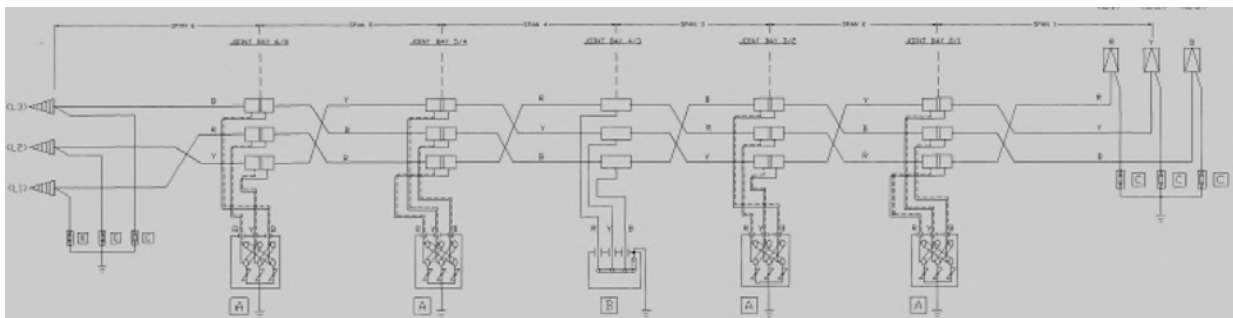

Fig.1: Bonding sections (representation of 1 circuit)

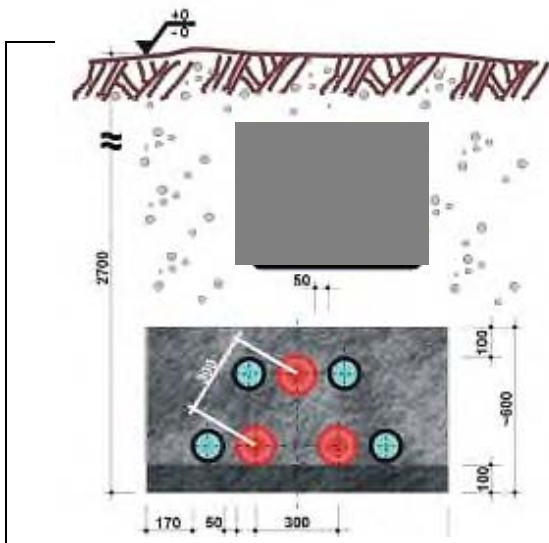

Fig.2: Arrangement of the cables (red) with cooling pipes (blue)



Fig. 3: Picture of the open trench under the pavement



Fig. 4: Picture of the tunnel laying with cable protected by covers (removed after completion)

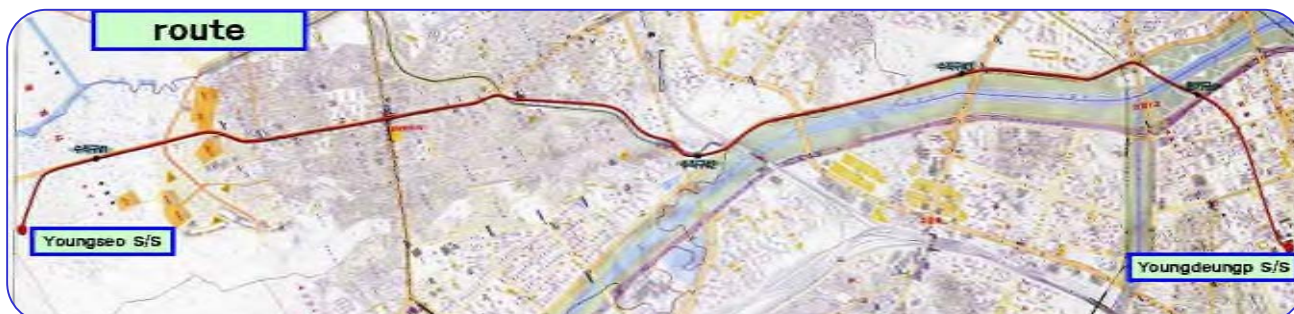

Fig. 5: Picture after completion, covering of bolted concrete blocks

## SP09: Youngseo-Youngdeungpo (Korea)

### Project overview

KEPCO was required to reinforce the electricity supply network in the South-western area of Seoul and Youngdeungpo area due to increasing demand for transmission capacity. The area is very densely populated and industrialized, so KEPCO decided to install 345 kV underground power transmission cables from Youngseo substation to the new Youngdeungpo substation.



### Project summary

345kV XLPE cables were selected because of their higher capacity and lower power loss compared with existing 345kV oil-filled cables. A 2000 mm<sup>2</sup> copper conductor was selected giving a rating of 955 MVA compared with 575 MVA for an oil-filled cable installed in a fireproof trough. The cable has a 27 mm insulation thickness and the cable and accessories had passed a long-term (one-year) prequalification test. Two circuits, 9.8 km long, were installed in a cable tunnel in trefoil arrangement with horizontal snaking. The tunnel was constructed by either the cut and cover technique or using a tunnel boring machine.



12 GIS terminations and 150 straight joints were required. It was the first use of prefabricated joints on 345kV XLPE cable in Korea.

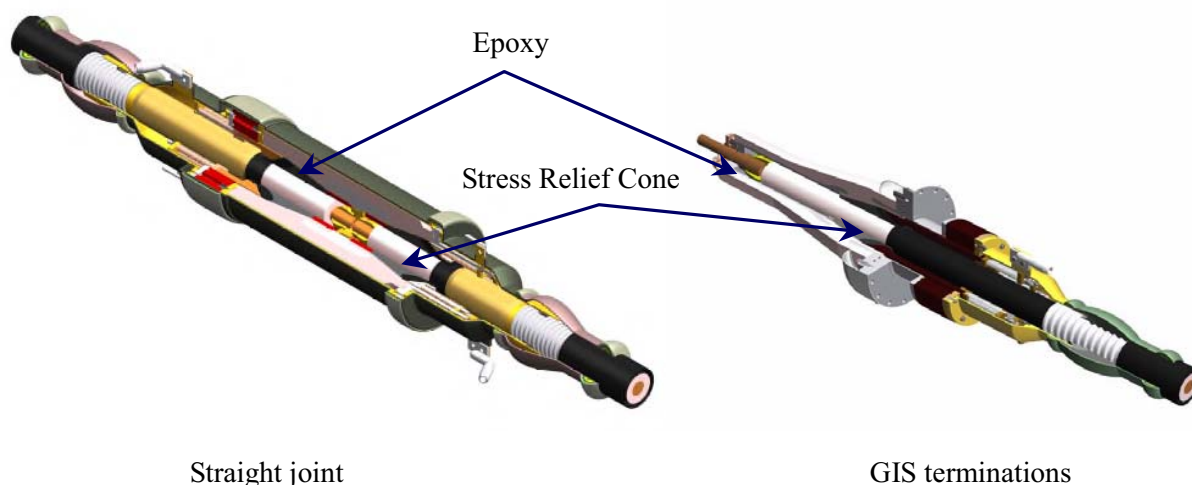

Straight joint

GIS terminations

Jointing was carried out inside a clean booth to ensure high quality. The controlled environment in the booth was monitored for particulate matter, temperature and humidity.

Installation work began in November 2002 and the cable began commercial operation in June 2003. After-laying tests included a dielectric withstand test and partial discharge test.

### SP10: 220 kV XLPE cable Lübeck-Siems (Germany)

When the HVDC Baltic cable between Germany and Sweden came into operation it was necessary to reinforce the high voltage network in Northern Germany. Originally planned was a concept that included beside Baltic Cable an interconnection to the TSO in former Eastern Germany (VEAG), a new power plant in Lübeck (to improve the reliability of supply in the Lübeck area) as well as the construction of a 380-kV overhead line between Krümmel and Hamburg.

With the dynamic changes in the European energy market since its liberalisation these projects were not realised.

To utilize the entire Baltic Cable capacity of 600 MW, a 220-kV-XLPE-cable between Siems and Lübeck was constructed in 2004. The route length is 10.2 km.

The reason for using a cable was the closeness to urban areas.

The main data are given in the table below:

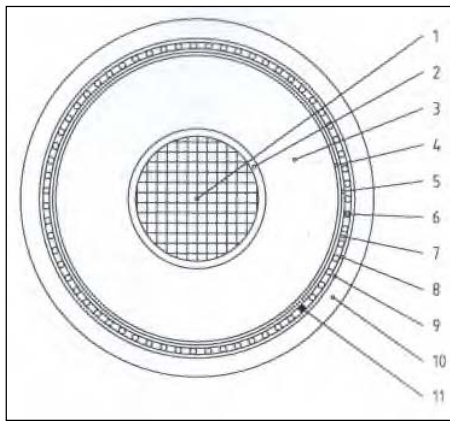

Nr.	Data	Material	Dimension
1	Conductor	Copper, Milliken	1200 mm <sup>2</sup>
2	Inner semiconductor	Extruded thermosetting sc-compound	
3	Insulation	XLPE (EHV)	21 mm
4	Outer semiconductor	Extruded thermosetting sc-compound	
5	Pad	Conducting tapes	
6	Screen	Copper wire	70 mm <sup>2</sup>
7	Longitudinal water sealing	Water blocking tape	
8	Pad	Conducting tapes	
9	Radial water sealing	PE-laminated AL-Tape	
10	Outer sheath	PE	5 mm
11	LWL-Element	4 Fibres	

In rural area the cable system was laid in trefoil section by open trench. The laying depth is 1.20 m.

In urban area it was laid in plastic pipes that are surrounded by steel tubes. The laying depth is up to 5 m.

The maximum current is 850 Amperes. For a short time (up to 5 days) the maximum current can be increased up to 900 Amperes.



## SP11: 380 kV diagonal connection through the load centres in Berlin (Germany)

In 1994, Bewag's insular existence came to an end when it was connected to the supraregional inter-connected grid (VEAG Wolmirstedt). Part of this connection consists of a new 380 kV overhead power transmission line and a new 380 kV oil-filled cable system which was used to provide an inner-city link-up with the Reuter substation in Spandau district. A 380 kV connection (overhead line and oil-filled cable) between the Reuter and Mitte substations, which had come into operation as early as 1978, enabled power to be supplied from the grid to the city centre of Berlin.

### The entire 380 kV diagonal link

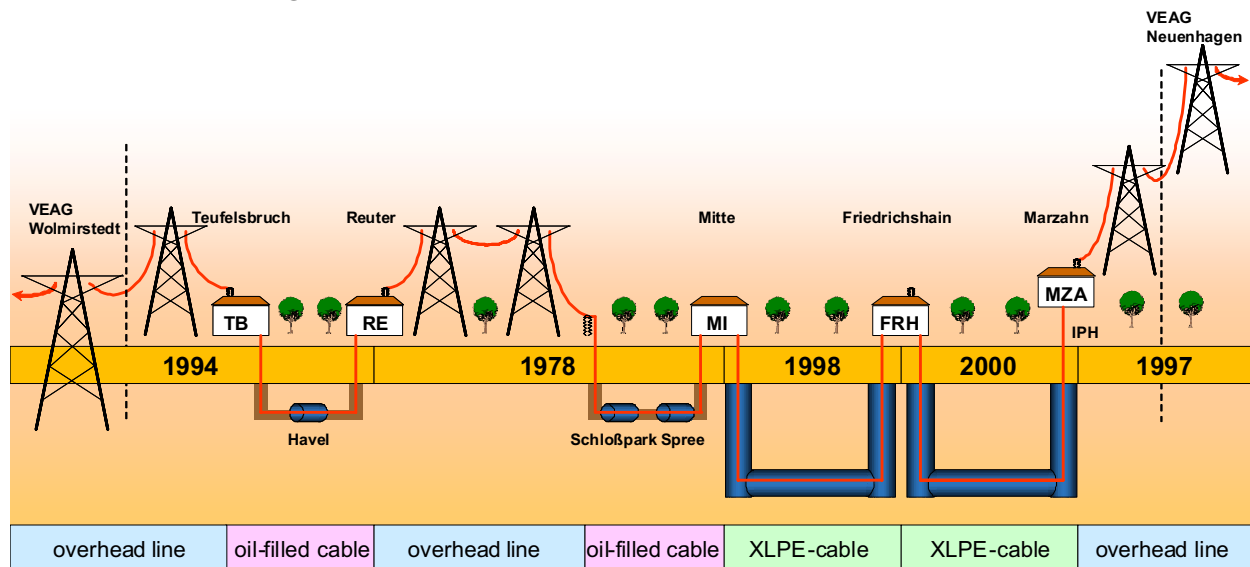

### 380 kV connection between Mitte and Friedrichshain substations

The extension of the 380 kV cable network to connect Mitte and Friedrichshain substations was originally to be carried out by analogy with conventional cut-and-cover methods, as had been the case with the 380 kV grid link-up.

The envisaged extension route ran mostly along public highways and cuts across various major construction sites (Potsdamer Platz, new government precinct, Friedrichstraße) and urban development areas at several points.

For all these reasons a feasibility study was carried out to establish whether it would be possible to have the planned 380 kV cable system installed in a tunnel linking the two substations. The position of the tunnel was then determined on the basis of geological reports, existing test drills and realized depth drills.

The tunnel runs at a depth of approx. 25 to 30 metres beneath the land surface. Its outside diameter is 3.6 metres and the inside width 3 metres. The tunnel is approx. 6.3 km long. The run is approx. 1.1 km shorter than it would have been if conventional construction methods had been used.

### 380 kV connection between Friedrichshain and Marzahn substations

The fourth section of the 380 kV diagonal connection between the 380 kV substation in Friedrichshain and the new substation in Marzahn stretches over a distance of approx. 5.2 km.

The new connection, which completed the diagonal link-up, went into operation in autumn of the year 2000.

## Partial discharge measurement during the start-up phase



The accessories now in use on the 380 kV side consist largely of prefabricated and pre-testable slip-on control fixtures. Ultimately, however, the quality of the accessories depends on their proper installation on the construction site. On-site testing is, therefore, absolutely essential. The measuring system consists of a sensor which can be fitted into the accessories. A special feature of this system is that the high-frequency partial discharge signals can be decoupled without the cable's insulation system or the accessory being impaired in any way. In view of the success of these

tests, Bewag has decided to include partial discharge measurements in the start-up checks on the 380 kV XLPE cable connection .

## 380 kV overhead power transmission line

A new overhead power transmission line of approximately 12 km was to be used for the final section of the connection which extends to the substation at Neuenhagen to the east of Berlin.

### The Diagonal Link of Berlin

Sction	1	2	3a	3b	4	5	6
Type of transmission technology	Overhead Line	Buried oilfilled cable	Overhead Line	Buried oilfilled cable	Tunnel laid XLPE Cable	Tunnel laid XLPE Cable	Overhead Line
Type of Cooling	Natural	Watercooled	Natural	Water-cooled	Air ventilated	Air ventilated	Natural
Length	1.1 km	7.6 km	2.6 km	8.1 km	6.3 km	5.2 km	12 km
Transmission Capacity per system	1800 MVA	1120 MVA	1800 MVA	1120 MVA	1100 MVA	1100 MVA	1800 MVA
Number of sites	3 towers	18 bunkers	8 towers	21 bunkers	5 shafts	3 shafts	25 towers
Space size	10x 10 mts	8x4x4 mts	10x 10 mts	8x4x4 mts	Tube outer diameter 3.6 m, 2000 sqm per shaft	Tube outer diameter 3.6 m, 2000 sqm per shaft	10x10 mts
Year commissioned	1994	1994	1978	1978	1998	2000	1997
Type and number of conductors	ACSR 4x 265/35	Al 1200 sqmm	ACSR 4x 265/3	Al 1200 sqmm	Cu 1600 sqmm	Cu 1600 sqmm	ACSR 4x 265/3

## SP12: 400 kV XLPE Cables for the biggest Pump Storage Power Plant in Germany

Vattenfall Europe Generation AG has built a pump storage power plant at Goldisthal in the Thuringian mountains. The power plant is the most modern pump storage power plant in Germany with its 1060 MW capacity and will be amongst the largest of its kind in Europe.

Pump storage power plants are used for the economic operation of the grid by providing electrical peak energy, improving of the grid control, by providing instant-reserve in case of shut-down of large power plants and by synchronous condenser operation for the reduction of the transmission losses in the grid. During periods of low demand, surplus energy from the grid will be used for pumping the stored water of the river Schwarza from the lower water reservoir into the upper reservoir. To cover peak load the gates of the upper water reservoir will be opened and the water drives the four 265-MW-turbines with the coupled generators. The 12 million cubic metres of water, stored in the upper reservoir, are enough to produce electrical energy with the four turbine generators for eight hours.

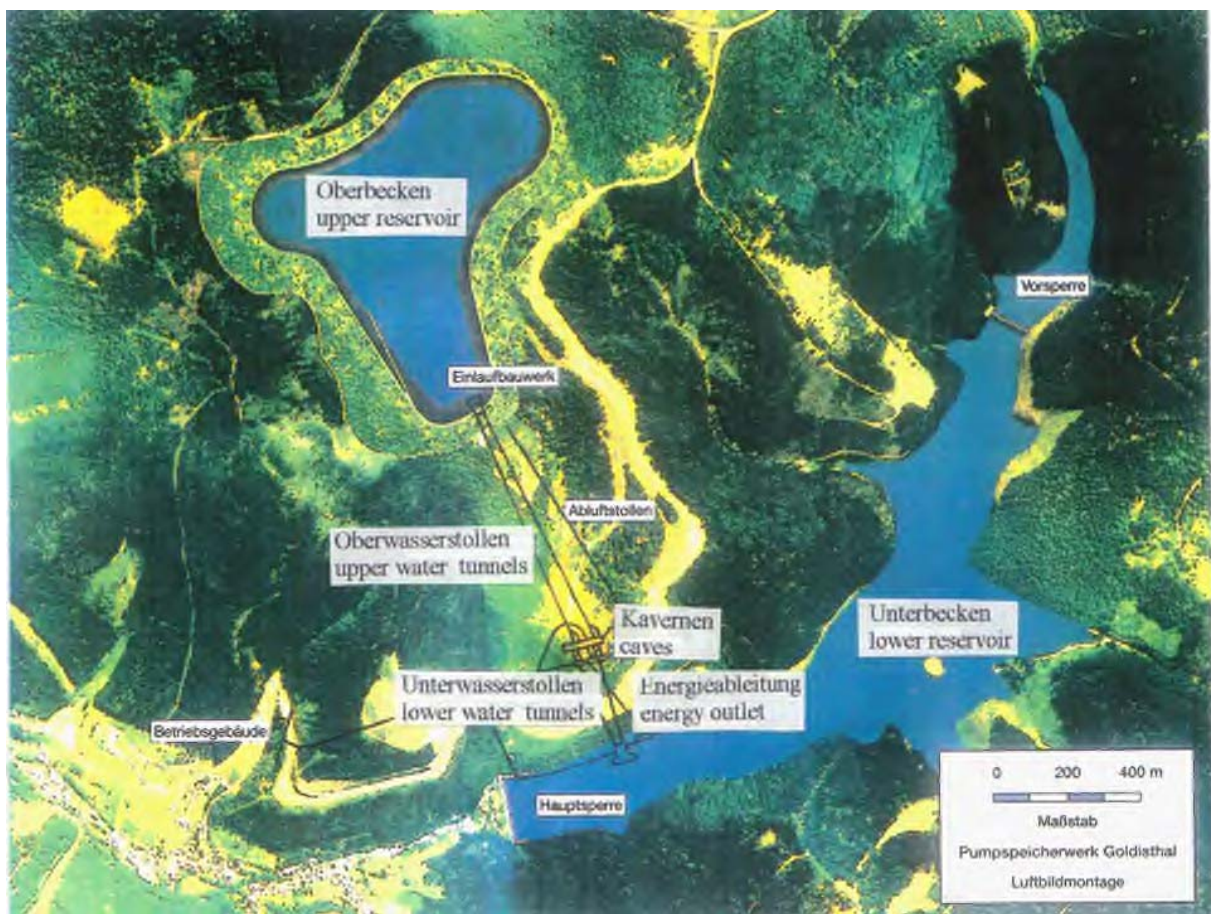

The task was to deliver and to install the 400-kV-XLPE-cables and accessories for the energy outlet including the earthing system. The energy outlet consists of 4 circuits 400-kV-XLPE-cables installed in a tunnel for the connection between the GIS in the transformer cavern and the GIS in the transition area to the overhead line.

The cablemaker was responsible for the design, supply and installation of 4 cable systems each approximately 400 m long, 24 metal enclosed GIS terminations and associated clamping systems and the earthing systems.



The cable has a 630 mm<sup>2</sup> conductor and 120 mm<sup>2</sup> screen. It is designed for a nominal rating of 400 MVA and a short circuit current of 90 kA for 1 second.

The cable is longitudinally and radially watertight with a laminated sheath. The outer diameter of the cable is 117 mm and it weighs approximately 16.5 kg/m. It was delivered on 3.8 m diameter drums. The weight of each delivery length (approximately 400m) was about 9000 kg (including the cable drum).

The metal enclosed GIS terminations have a cast resin insulator and a deflector cone of EPDM. The point of intersection to the GIS is according to IEC 60859. All terminations are equipped with sensors for partial discharge measurements.

The 4 cable systems run from GIS in the transformer cavern through a slant tunnel in the mountain (cross section 4 m x 4 m, slope 23%) upwards to the GIS in the transition area to the overhead line.

Laying and mounting of one cable system requires approximately 2 months.

Type and routine tests for the cables and terminations were requested to DIN VDE 0276-632 and IEC 62067. After installation of the 4 cable systems on-site tests were made with 450 kV ac for 1 hour and in addition partial discharge tests at 450 kV. The on-site tests for the first two cable systems took place in July 2002. The third and the fourth system were tested on-site successfully in October 2002. Since July 2002 the systems 1 and 2 are in service providing electrical energy for testing the large motor-generators of the power plant. All four systems were in service from 2004.



GIS terminations in the transition area

## SP13: The World's First Long-Distance 500 kV XLPE Cable (Japan)

### Overview

A plan has been developed to supply the growing power needs of central Tokyo directly with 500 kV underground circuits using XLPE cable, which has a number of advantages over oil-filled cable. In this project, extending over a period of several years, a compact cable for long-distance circuits with an insulation thickness of 27mm (no larger in diameter than oil-filled cable of comparable rating) has been developed, together with associated extrusion-molded joints (EMJs). Tokyo Electric Power Co. decided to use the cable and joints in the Shin-Toyosu Line (39.8km, 2circuit).

### Design and structure of cable

Based on various design parameters and the insulation characteristics of the treated portion of the insulation shield for EMJs, it was determined that the insulation thickness required for the cable would be 27mm, the conductor size was 2500 mm<sup>2</sup> and the metal sheath was of corrugated aluminum.

### Technical Details

The Shin-Toyosu Line is a 39.8 km underground transmission route connecting the Shinkeiyo Substation on the 500kV overhead grid line system surrounding Tokyo, to the Shintoyosu Underground Substation newly constructed in central Tokyo. This is the first time that 500kV XLPE cable has been used on a long-distance circuit anywhere in the world and it is the longest underground transmission link in Japan. Virtually the entire route, with the exception of ducts under bridges and elevated expressways, is enclosed in a tunnel. Part of the route runs along the shore of Tokyo Bay and advantage was taken of this fact by transporting long-length cables from the factory by sea, and laying them from a base yard situated at the landing point, thereby minimizing the number of joints.

The specifications are as follows

- Number of circuits 2 ( 3 in future)
- Transmission capacity 900MW/cct
- (1200MW/cct in future)
- Laying configuration : Trefoil formation in tunnel troughs, and in ducts under bridges and elevated expressways.
- Number of intermediate joints per phase 40
- Type of joints EMJ
- SF6 gas-immersed sealing ends : Silicon oil impregnated.

For the part of the route along the shore of the bay, where both duct and tunnel existed, the use of the base yard was impracticable. Thus long-length cables delivered by sea were reloaded onto a special trailer equipped with a pay-out machine and transported for the very short distance overland to the pay out point. In order to allow laying operations on roads even when using large drums, a traverse method was developed and implemented whereby the space occupied on roads during installation was reduced and cable of about 1200-m in length could be laid.

The world's first 500kV long-distance underground transmission link using XLPE cable has operated since 2000.

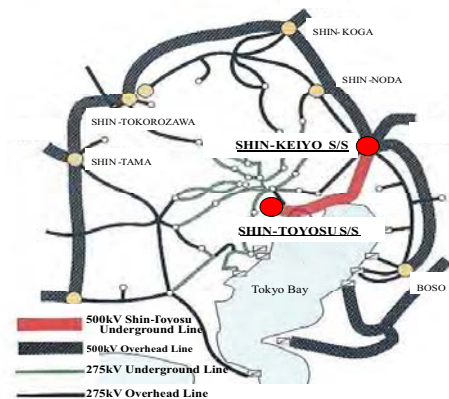

Fig.1 Cable route



## SP14: Construction of a 275kV underground transmission link composed of continuous 2,500m long cable (Japan)

### Overview

Kawagoe-Nishinagoya Line is a 275 kV underground transmission link consisting of 2 circuits 14.4km in length. The whole link is installed in a tunnel, in order to achieve a high reliability of power transmission from Kawagoe power station to Nishi-Nagoya substation, in the Chubu area, Japan.

### Cable design

Kawagoe-Nishinagoya Line was installed in a tunnel, which is composed of Chubu Electric's Tunnel (Diameter: 4.2m, Length: 9.8km) and common-use tunnel (Diameter: 4.9m, Length: 4.6km). Its transmission capacity is 810 MW per circuit. Ultra long XLPE cable, which has 2,500mm<sup>2</sup> copper conductor and stainless steel sheath and is 2,500m long, was developed to reduce cable joints.

### Technical Details

Some state-of-the-art technologies containing the “Ultra Long Cable”, which is the longest in the world for this kind of cable, was developed and contributed a lot to reduce our construction cost.

- To absorb the cable thermal expansion and contraction vertical snaking was adopted. A combined cable bracket and cleat was developed, leading to a weight saving and a decrease in the numbers of parts.
- The cable container whose total weight was about 140 ton including a cable was transported to the pier of Kawagoe Power Station by the ship. It was unloaded onto the pier by the floating crane of 300 ton. and it was transported to the installation base in the power station by the transporter.
- The installation base provided a cable slacking area to absorb the speed difference between the speed of the container rotation and the speed of the construction equipment in the tunnel, which saved space. As a result, the construction period was reduced from about 12 months to about 10 months.
- F-EMJ (Flexible-Extruded Mold Joint) and O-EMJ (One-processed Extruded Mold Joint) were developed and installed to improve the reliability of the joint, which is constructed by extruding a polyethylene material into the mold, forming an insulation layer, and reinforcing the insulation layer by cross linking.
- To make the cable length longer, manufacturing process of stainless steel sheath was improved. Ultra long cables helped to reduce the number of the joints from 16 sets, which are required when cable length is 1,800m, to 10 sets, to shorten the construction period by 2 months, and to save the cost by about 10%



Fig.1 Laying Cable

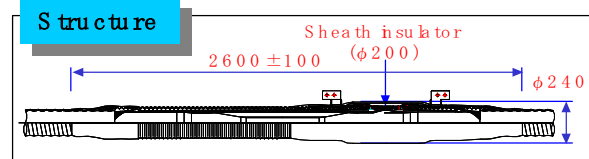

Application of 500kV EMJ technologies  
Downsizing the joints by welding the conductor



Diameter : φ400mm → φ240mm

Fig.2 F-EMJ

## SP15: Installation of a 275 kV 3.3km gas-insulated transmission line for underground large capacity transmission (Japan)

### Overview

The SF<sub>6</sub> gas-insulated transmission line (GIL) was applied to the 275kV Shinmeika-Tokai Line, which can transport 2,850 MW per circuit with cooling in a 3.3km tunnel. To transport this large capacity, only two circuits are needed for GIL. GIL has four times greater current capacity than a cross-linked polyethylene(XLPE) cable line, while adoption of XLPE cables requires five circuits.

### GIL design

An underground transmission system was adopted due to the difficulty in finding a route for an overhead transmission line and environmental coordination around a power station. The tunnel was constructed at a depth of about 30m under public roads. The GIL's conductor is an aluminum alloy pipe and 20mm thick. Suitable design and structure were developed to install GIL along the three-dimensional curves of the tunnel and to absorb the displacement due to the thermal expansion, contraction and possible earthquake.



Fig.1 Cable route and section

### Technical Details

Installation techniques were developed to fix and joint GIL units in the narrow space and the dusty environment.

The joint was designed to absorb the unavoidable small dimensional errors that are caused during tunnel construction and angle errors of curved GIL unit which could be caused by manufacturing process,

The maximum unit length was limited to 14m due to the manufacturing process of extruded aluminum pipes for the enclosure and due to their transportation restrictions.

The length of one section for expansion absorption was determined so that the thermal expansion and contraction of the enclosure and the conductor, and the displacement due to an earthquake can be absorbed.

The 56m unit section for expansion absorption is identical to a gas compartment for gas treatment and for gas sampling in case of accidents.

The enclosure was bonded solidly at the both ends of line to prevent electromagnetic induction problems on adjacent control cables, iron losses in the supporting structure, and enclosure induced voltage.

Features of installation are as follows.

A full automatic welder was developed to maintain constant quality at various welding points.

A compact clean room, which moves on rails to every jointing site, was developed to secure the same clean environment as in a factory when each unit is jointed in a tunnel.

A bogie which can move on rails was developed to mount GIL units onto supporting structures and which can fit the unit to the adjacent one by adjusting the position of the unit within the order of millimeter to save manpower and improve precision during the mounting and fitting procedure.

A cart that could travel on rails in a tunnel was developed for loading equipment to make dry air needed for a gas pressure test at every 56m gas compartment and vacuum equipment to evacuate the gas compartment before filling SF<sub>6</sub> gas.



Fig.2 Gas compartment and structure for absorbing due to thermal expansion and an earthquake displacement

## SP16: Koksijde – Slijkens 150 kV Link (Belgium)

### Overview

The connection between Koksijde and Slijkens by a 150 kV underground cable is part of a group of projects aimed at reinforcing the coastal region of Belgium. This region faces a number of different challenges:

- A lot of new generating sites have been announced (several wind farms will be built in the North Sea in the coming years);
- The transmission capacity of the existing 150 kV overhead lines is becoming saturated, making it difficult to ensure the power supply of the coastal region;
- The 70 kV-grid has to deal with voltage problems due to saturation;
- Both Koksijde and Slijkens are substations in antenna on one 150kV overhead line; so, the reliability becomes endangered.

Several projects have started up to solve these problems:

- Reinforcement of the region (important 400 and 150 kV substations) by upgrading and uprating a 70 kV line up to 150 kV;
- Reinforcement of several substations by upgrading HV transformers and installing new 150 kV bays;
- A new 150 kV underground cable connection between Koksijde and Slijkens with a total length of 33 km.

The project was launched in the year 2000 but was surrounded by uncertainties over the amount of power likely to be produced by the wind farms (at the time of writing, none of the planned wind farms have been constructed) and difficult negotiations with the administrations to agree upon a route. As a consequence, the project only really got launched in 2003. After obtaining the building permits in the early days of 2005, the contractors started work in February 2005 and pulled the last cable one year later. The energizing of the link is foreseen in May 2006.

### Circuit details

#### Thermal environment

A special study of the underground thermal behaviour at several points was performed to optimise as much as possible the ampacity (340 MVA), taking into account the defined conductor cross-section of the 150 kV cables (2000 mm<sup>2</sup> Aluminium conductor XLPE), one with integrated optical fibres:

- Use of special controlled backfill;
- Replacement of a bad 50 cm thickness ground layer on a length of 3.5 km;
- Filling of all the ducts for crossings with a bentonite-sand-water mixture;
- Direct cross bonding of the screens.

#### Tunnel laying: snaking



The link crosses the Ostende-Brugge channel through an existing technical tunnel before reaching the substation of Slijkens. This concrete tunnel has a horizontal part of 120 m length with 25 m-depth shafts at each side.

For the horizontal part, the cables are suspended every 5 m, in trefoil formation, with a controlled sag (offset) equal to one cable diameter.

For the vertical parts, the cables are attached in flat formation following a sinusoidal path of which the inflection points are fixed.

A special fire retardant coating has also been sprayed onto the cables.



### Accessories

The accessories used on the link are the following:

- The terminations at the Koksijde side are composite outdoor type
- The terminations at the Slijkens side are new dry type GIS terminations
- The joints are cross-bonded (direct cross-bonding, i.e. without SVLs).

### AC - test conditions for the 33 km link: 2U<sub>0</sub> 15 min

The link has been divided in 3 parts of about 11 km length, which have been tested with two injection points: one at the Koksijde substation and the other at 2/3 of the link, at a specially equipped joint bay.

Tests were carried out on part 1 from the 150 kV outdoor terminations at the Koksijde substation, up to the “stop” joints bay and, on part 2 and 3, from the joint bay equipped with temporary (water) terminations.



### **Environmental concerns**

Taking into account the characteristics of the region (Belgian coast), the option of installing an overhead line has not been considered.

### Inventory and biological evaluation of the verges

The route of the link follows several roads in a rural area and crosses some agriculture parcels. The proposed route was submitted to AMINAL, the environmental department of the Flemish government. This authority ordered an inventory and a biological evaluation of the verges of the roads where the link would be installed in order to find an agreement on the way to limit the possible damage to vulnerable vegetation.

### Soil handling

In order to control the propagation of soil pollution, the Flemish government has formulated instructions for soil handling. All actions have to follow a specific process (digging up of the soil, transportation, storage in the final destination). The “chain care system” is aimed at preventing the spread of polluted soils to clean (or less polluted) areas.

## SP17: Pioltello - AEM Milano (Italy)

### Overview

For the 220 kV “Aem Trasmissione S.p.A” transmission grid it was decided to underground part of the overhead lines between Cassano and the “Milano Ricevitrice Nord” stations. This required the installation of two cable systems each of them approximately 3 km long. This connection is the undergrounding (siphoning) of the part crossing the most dense populated area of a 20 km long line in the area of Pioltello (a suburb of Milan). The transition between the overhead line and the underground cable was mounted directly on the terminal pole by using terminations with composite polymeric insulators.

### Technical details

The cables were designed to carry a continuous current of 950A for each circuit. This needed a single core 1600 mm<sup>2</sup> cable, aluminium conductor, XLPE insulation type, welded aluminium sheath and extruded polyethylene outer sheath, graphite coated. Metallic sheaths were connected in a cross bonding system (three minor cable sections) and a single point bonding system (two cable sections) for a total of five cable lengths for each circuit.

The cables were mainly directly buried in a single trench, surrounded by appropriate materials to guarantee their thermal environment.

Special magnetic field shielding has been provided where necessary for some part of the route in order to respect the requirements of Italian Law.

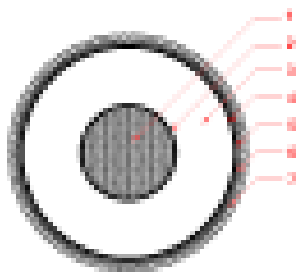

- 1 Compacted aluminium conductor
- 2 Semiconductor
- 3 XLPE insulation
- 4 Semiconductor
- 5 Waterblocking
- 6 Welded aluminium sheath
- 7 PE outer sheath

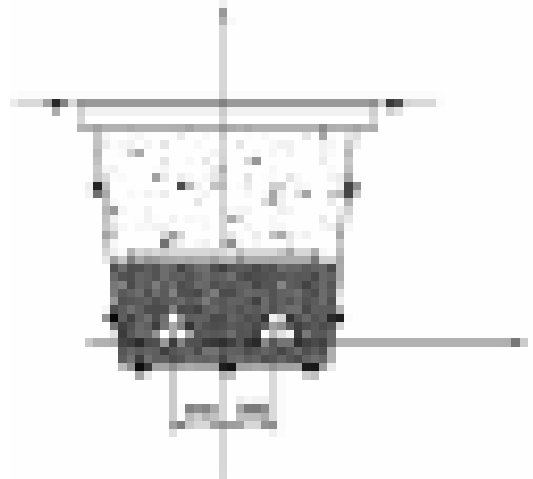

The overhead to underground transition has been realised on both sides of the circuit directly from the last pole without the application of surge diverters as the cable is self protected against the lightning and transient overvoltages.



## SP18: The Madrid “Barajas” Airport Project (Spain)

### Introduction

Madrid Barajas airport is being re-developed with the construction of two new runways and terminal and satellite areas. Intrusion of a nearby double circuit 400 kV overhead line on airport operations and possible radio interference with automatic navigation systems has led to part of the line being undergrounded. The underground cables are laid in a 12.8 km long prefabricated tunnel. Cable and GIL solutions were compared and XLPE cable selected as the most competitive solution. The overhead line rating (1390 MVA summer /1720 MVA winter) can be met using one cable per phase, with two circuits inside a tunnel, equipped with forced cooling.



Tunnel under construction

### Thermal requirements

The high rating of the circuits requires a 2500 mm<sup>2</sup> copper conductor and a forced cooling system, which includes 5 fan stations, distributed temperature sensing (DTS) to measure circuit and tunnel temperatures and a real-time thermal rating (RTTR) system that commands and integrates all subsystems. The forced cooling system is designed for a summer air intake temperature of 35 °C, maximum tunnel air temperature of 50 °C and maximum air speed of 5 m/s. The limiting parameter is the temperature of the 400 kV cable joints. The tunnel temperatures (air at the top of the tunnel and hottest cable) are continuously monitored by the fibre optic DTS

system. The RTTR interfaces with the DTS and controls the cooling fan speeds. Circuit parameters, such as load, temperatures, surrounding environmental conditions, etc. are continuously monitored by the RTTR system to calculate in real time the maximum loads (steady state and short term overload) that could safely be applied to the circuits.

Cable sheath bonding consists of a combination of 5 x 3 cross-bonded sections 810 m long and two single point bonded lengths at the ends (300 m at one end and 400 m at the other). This configuration ensured the manufacturing of 90 drums of identical length and eventual route changes adopted during civil works construction have been absorbed by these cable ends.

### Installation details

The technical solution that meets project electrical and thermal requirements consists of a 2 m x 2.25 m tunnel buried at an average depth of 2 m. The cable circuits, supplied by two manufacturers, are laid in a vertical configuration, one at each tunnel side with a phase separation of 0.5 m. Due to high mechanical stresses present in the cables with load variations, a flexible cable laying (snaking system) was chosen to minimize longitudinal and radial stresses on cable and accessories. Cables are fixed on metallic supports fixed to tunnel walls every 6 m. The cables rest on saddles and brackets and are tied together by means of three phase spacers at the 3 m intermediate point between two supports. Spacers are used to reduce electrodynamic forces generated during a short circuit. Sag applied to cables after laying is equal to 0.25 m. All metallic supports used for cable laying have been designed to resist maximum electrodynamic forces during a short circuit.

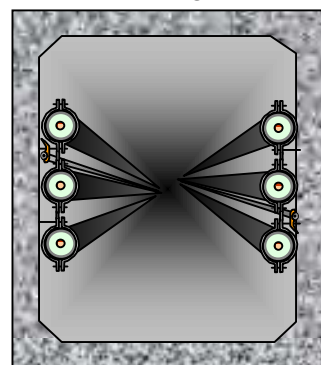

Lavout of cables

## SP19: Mechanical laying of HDPE ducts in a rural area (France)

### Introduction

In order to develop the laying of cables in the private land (essentially in rural area), to reduce the constraints of traffic during the works, and finally to reduce the cost of the underground lines, RTE has used for the CHABOSSIÈRE - MONTLUC link an innovative technique which allows to get the acceptance of the route by the public more easily: the mechanical laying of HDPE ducts.

### General presentation of the project

The 63 kV underground link is 10 km long and composed of three 400 mm<sup>2</sup> Al XLPE aluminium sheathed cables. About 8 km are constructed in rural area and about 2 km in urban area.

The laying techniques are:

- in urban area : PVC ducts covered with concrete. In this area, traditional techniques are used.
- In rural area: HDPE ducts directly buried. In this area, the mechanical laying of the ducts is used.

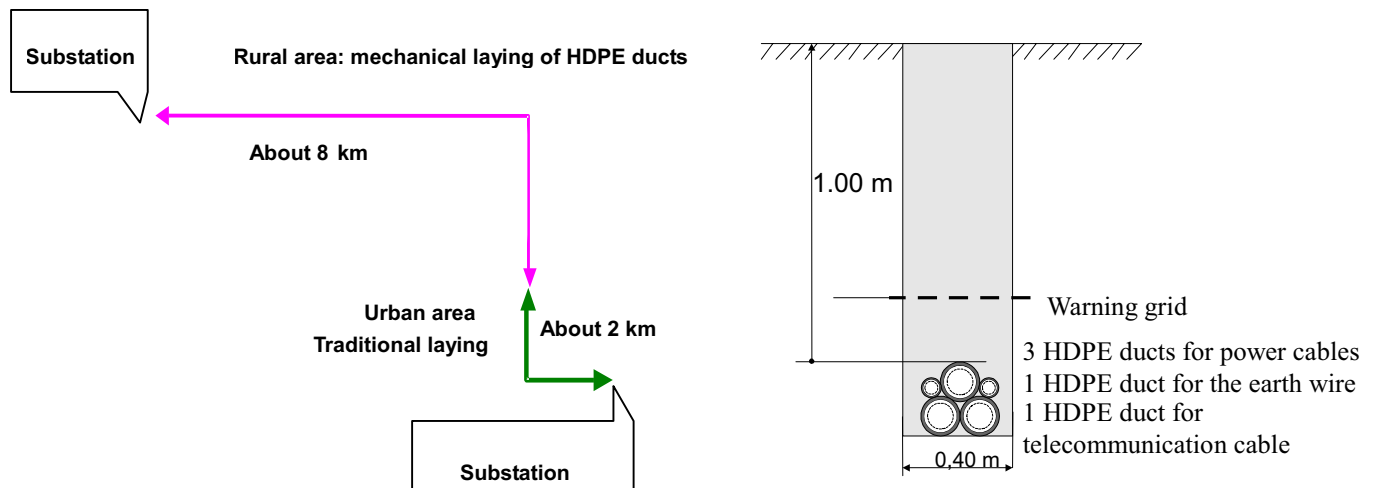

### Description of the mechanical laying technique

The technique, directly inspired from the laying of the telecommunication cables, is based on the use of a laying “train” which allows the mechanisation of the main phases of the works:

- trench opening with a trenchdigger,
- laying of the three ducts for power cables (beforehand strapped) with the drum-carrier and the cubicle tray,
- backfilling of the trench with the excavated earth.

The high quality of the HDPE ducts will contain the energy released by a short-circuit. The joints for HDPE ducts coming from two different drums are made with couplers which are electrically welded on site.

Ducts are wound round drums that can contain lengths up to 600 m for  $\varnothing$  125 mm ducts. Logistics for their delivery must be carefully managed. Drum-carriers transport the drums to the laying site and unwind the ducts a few metres in front of the trenchdigger.

The trenchdigger is the main element of the technique. The machine equipped with a big wheel that “crumbles” the ground. Extracted materials are laid on both sides of the trench. Then, the extracted earth is either used to backfill the trench, or levelled around.



### **Advantages of the technique**

- the length of the opened trenches and the duration of the trench opening are reduced,
- no human operation in the trenches is necessary. It leads to the following advantages :
  - the width of the trenches is reduced, as well as the volume of extracted earth,
  - avoiding the need for trench sheeting.
- reduction of tracks as the excavated earth is re-used to backfill trenches and as no materials are taken away or brought to the working site,
- significant cost reduction.

### **Limits of the technique**

In spite of all the advantages this technique can offer, the use of the mechanical laying has to meet several requirements :

- the length must be over to 3 km to become profitable,
- crossing of underground networks must be avoided, or at least, this technique needs a very precise study of existing networks in order to avoid accidents.
- the linear continuity of works is necessary in order to avoid machine immobilisation (preliminary agreements of all land owners are necessary),
- the technique cannot be used with some specific cultures (vineyards, fruit-trees,...), works are forbidden during the wet seasons, and clay soils are forbidden because of the bad quality of backfills.

### **Conclusion**

Laying in rural area was made according to the mechanical laying principles described above.

The duration of works for the total length in rural area (7.9 km) was three weeks and two days, which leads to an average rate of 500 m/day. As a comparison, the rate is between 50 and 300 m/day with a traditional technique.

The only problems met were to replace broken teeth on the wheel.

Except for these minor problems, RTE is generally satisfied with the use of this technique because of the reduction of the duration of works and the good relations with the land owners.

## SP20: Land cable connecting to the SARCO submarine link (Sardinia-Corsica)

### Overview

The islands of Sardinia and Corsica are partly connected through the old 200 kV DC cable installed in the early sixties. The need to improve power interchange between the two islands requires a new connection to satisfy the highly increased energy demands of these two tourist sites.

### Technical details

The choice for the connection is a 150 kV XLPE AC cable having a 400 mm<sup>2</sup> copper conductor. The total length of the connection is 31 km and is composed of 11 km of land cable on Corsica, 15 km of submarine cable and 5 km on land in Sardinia. The nominal continuous rating is 150 MVA. For the submarine part a three core armoured cable has been selected, while for the land part single core cable was chosen.

The maximum sea depth is 75 m. The submarine cable was buried in the sea bed in order to prevent mechanical damage. Near the coast of Sardinia, additional cast iron shell protection has been applied. The land cable was laid flat (at 200 mm spacing) and directly buried in trench at a depth of 1.4 m. The metallic screen was cross bonded.



Submarine cable



Land cable

An additional fibre optic cable, for data and signal transmission, has been placed in the interstice between three cores of the submarine cable. The external overall diameter of the three core submarine cable was 207 mm, the weight in air 75 kg/m and the weight in water 48 kg/m. The Corsica and Sardinia 50 Hz AC grids needed to be synchronised before switching on the system.

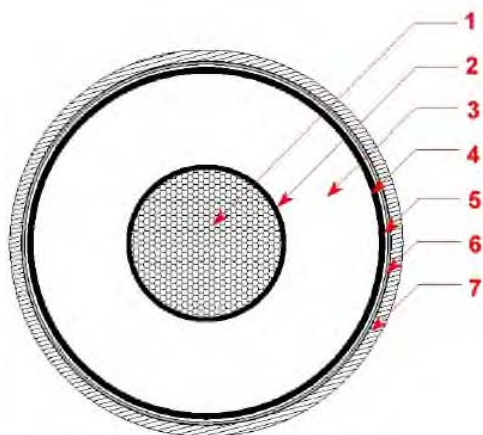

#### 150 kV land single core cable design

- 1- 400 mm<sup>2</sup> copper conductor sealed
- 2- Semiconductor
- 3- XLPE insulation
- 4- Semiconductor
- 5- Waterblocking
- 6- Welded aluminium
- 7- Pe outersheath

The design of the land and the submarine cable core is similar, this facilitates the transition jointing between the single core land cable and the three core submarine cable.

## SP21 : Bethel – Norwalk 345 kV Transmission Project (USA)

### Project Description

The Connecticut Light and Power Company (CL&P) proposed this project to enhance electric reliability and service to southwestern Connecticut by extending its 345 kV transmission system from Plumtree Substation, located in the Town of Bethel, to Norwalk Substation, located in the City of Norwalk.

Southwest Connecticut is a robust economic area. It has been growing faster than the rest of the state, and its residents consume relatively more power, on average and at peak times, than those elsewhere in the state. Yet this area is geographically isolated from the region's 345 kV electric transmission grid and generation sources; and the southwest corner of the state – the Stamford/Norwalk/Greenwich sub-area – has limited generation. CL&P along with state and federal regulators have recognized this geographic isolation, and regional needs for reliable electric power supplies to support both existing and projected load growth.

The Bethel/Norwalk project addresses part of this isolation, integrating southwestern Connecticut with the New England bulk power grid. CL&P is constructing the second leg to this loop from the north with a line from Middletown to Norwalk.

The Bethel to Norwalk 345 kV transmission project provides added capacity to serve the growing demands for electricity in the southwestern portion of the state, and will provide better opportunities for moving power to customers within the state for access to power from other Northeastern states. Specifically, the project will achieve the following:

- Improve reliability by providing a new path for bulk power to flow into the area,
- Increase capacity to a transmission-constrained area, responding to southwestern Connecticut's demands for electric power,
- Reduce existing transmission congestion and related costs which exceeded \$300 million last year in the Connecticut sub-region of the New England Power Pool (NEPOOL), and which are expected to grow significantly in the next few years, in the absence of new power supply to the area,
- Provide greater access to competitively priced generation, and
- Accomplish these objectives by a means that strikes the appropriate balance between the lowest reasonable cost to consumers and the lowest reasonable environmental impact.

Construction began in March, 2005, and the line will be handed over to Operations in October, 2006.

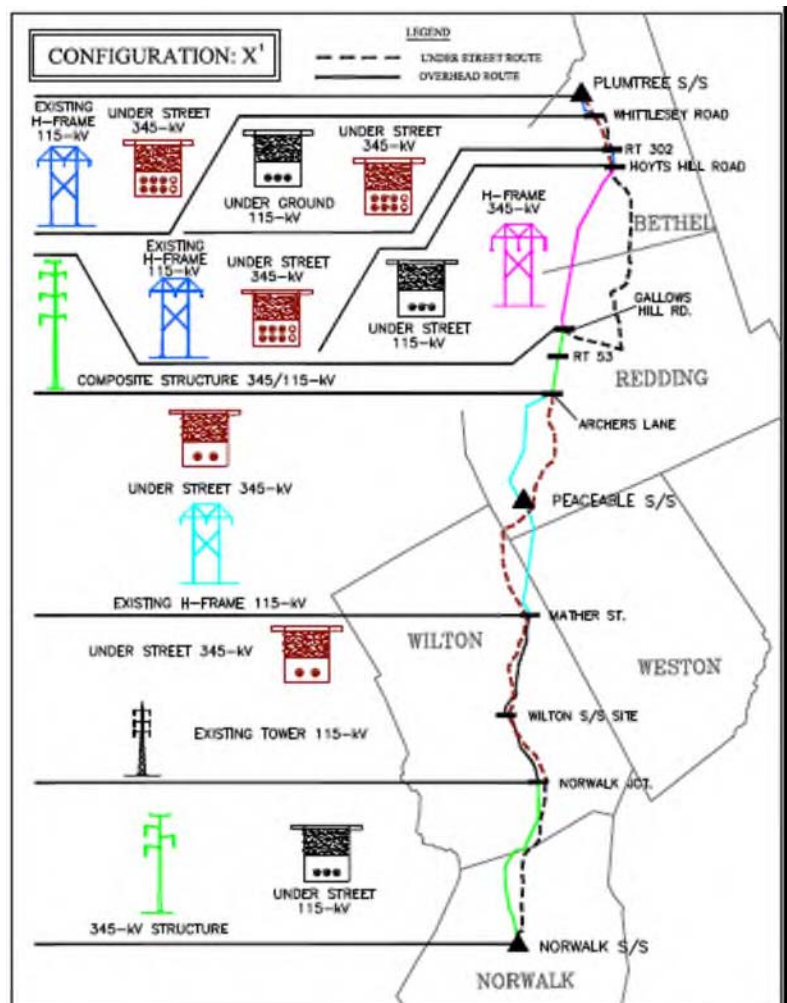

## Project Considerations

CL&P has an existing transmission corridor between the Plumtree Substation in Bethel and Norwalk Substation in Norwalk which is approximately 20 miles (32 km) long and varies in width between 80 and 150 feet (24-45 m). An existing 115 kV transmission line occupies the entire length of the right-of-way between Plumtree and Norwalk substations; for 3.7 miles (6 km) between Norwalk Junction and Norwalk Substation this circuit shares the right-of-way and support towers with one or more of two 115 kV circuits and a 27.6 kV circuit. Leaving the existing lines in place and constructing a new 345 kV line alongside was rejected over most of this route because too much additional right-of-way width – up to an additional 45-110 feet (14–34 m) was needed. Its cost and potential home takings were strong considerations. To minimize the necessary right-of-way expansion, the project initially proposed removing a 115 kV circuit and rebuilding it on common steel poles with the new 345 kV line, each in a vertical configuration. This proposal would require much taller poles, and that was a cause for significant public objection during the siting process. Building underground lines over the entire route was not technically feasible or practical.

Numerous configurations of the new 345 kV and modified 115 kV lines were evaluated during an extensive state siting process. The final configuration approved by the Connecticut Siting Council was called “X prime”. This final configuration employs two separate segments of underground and two segments of overhead.

## Project Components

The 115 kV cable system as part of the Bethel to Norwalk 345 kV transmission upgrade project comprises approximately ten circuit-miles (16 cct-km) of 3000 kcmil (1520 mm<sup>2</sup>) copper conductor, XLPE cable buried in three different sections under local and state roads in the towns of Bethel, Redding, Wilton and Norwalk. Work on this underground installation began in March, 2005 and completed in June, 2006. There are 26 vaults, each of which is 9 feet wide by 25 feet long (2.7x7.6m).



**HPFF Cable Installation**

The 345 kV cable system as part of the Bethel to Norwalk 345 kV transmission upgrade project includes both high-pressure, fluid-filled (HPFF) cable and XLPE cable. Both of the 345 kV cable portions are double circuit. The HPFF segment is 9.7 circuit-miles (15.5 cct-km) of 2500 kcmil (1267 mm<sup>2</sup>) copper, and the XLPE segment is 2.1 circuit-miles (3.4 cct-km) of 1750 kcmil (887 mm<sup>2</sup>) copper. Both are installed under local and state roads in the towns of Bethel (XLPE), and Redding and Wilton (HPFF). The HPFF system includes 20 vaults total, each of which is 6 feet wide by 18 feet long. The XLPE system includes 6 vaults per line (or 12 vaults total), each of which is 8 feet wide by 30 feet long (2.4 x 9 m). Work on the HPFF-portion of the project began in March, 2005, and work on the 345 kV XLPE portion began in March, 2006. Both installations were completed in October, 2006.



## SP22 :Jefferson – Martin 230 kV Single Circuit Transmission Project (USA)

### Project Description

The objective of the Pacific Gas & Electric Jefferson – Martin Project were fourfold: (1) to meet future demand and reliably serve the San Francisco and north San Mateo County areas under normal and reduced generation scenarios; (2) to comply with industry planning criteria of the California Independent System Operator (ISO) and the North American Electric Reliability Council (NERC); (3) to create a more diverse transmission system in the area by providing a second independent major transmission line pathway in the area; and (4) to implement the ISO Board of Governors' April 2002 Resolution that approved the Jefferson – Martin Project for addition to the ISO-controlled grid.

The new transmission line is approximately 27 miles (43 km) long. The cable sections comprise a total length of 24 miles with 3 miles of overhead line between the cable sections. The transition from overhead to underground is by use of single pole shaft riser transition structures. The transmission line is operated at a nominal voltage of 230 kV, and designed to carry a minimum load of 420 MVA with a continuous emergency rating of 478 MVA.

The new Jefferson – Martin 230 kV transmission line is located on the San Francisco Peninsula. It begins near the Town of Woodside in unincorporated Redwood City and crosses the Town of Hillsborough and Cities of Burlingame, Millbrae, San Bruno, Colma, South San Francisco, Daly City and Brisbane. The underground line is located within city streets nearly the full alignment.

Construction began on January 25, 2005 and the project was released to operations on April 29, 2006.



### Project Components

The 230 kV transmission line is comprised of two underground segments separated by one overhead segment. The southern 12 miles (19 km) of line, beginning at the Jefferson Substation, is an underground circuit, with one 790' (240 m) overhead span about 6.8 miles (10.9 km) from Jefferson Substation. This overhead span crosses an historic dam and is designed to be replaced by a cable system in the future after construction of a new bridge at this location. The middle 3 miles (5 km) of transmission line is an overhead circuit installed on new tubular steel poles which also support a rebuilt 60 kV circuit along the corridor. The northern 12 miles (19 km), terminating at Martin Substation, is an underground cable system.



The underground cable system is comprised of 2500 kcmil (1267 mm<sup>2</sup>) copper solid dielectric XLPE cables and cable accessories (splices,

terminations, grounding, etc.) appropriate for installation in a buried concrete-encased PVC conduit duct-bank system. The cable design is made of a five or six segment copper conductor, 23.4 mm of XLPE insulation, 2.8 mm of lead alloy sheath and an overall MDPE jacket. The outer diameter of the cable is 117 mm and it weighs 30 kg/m. Single-mode fiber optic fibers are embedded in the power cable to allow continuous temperature monitoring via a distributed temperature sensing (DTS) system to obtain real time thermal rating of the cable system. Cable splices are located in single circuit splice vaults along the route. One separate communication fiber optic line is installed the entire length of the transmission line and contains 144 individual single-mode fibers.

The project included 80 underground splice vaults, each 6.7 m x 2.4 m x 2.1 m in size. A total of 234 joints and 18 terminations were installed. The cable sheath was grounded using cross-bonding for the majority of the circuit, and single-point bonding in some instances.

The overhead transmission line segment consists of tubular steel poles. Conductors are high temperature ACSS type conductors. The overhead transmission line required rebuilding portions of an existing PG&E 60 kV circuit.



The typical duct bank consists of four 6-inch (15 cm) PVC ducts and two 4-inch (10 cm) PVC ducts encased in concrete. The concrete encasement and fluidized thermal backfill were specially designed utilizing locally available materials to provide a good thermal environment for the cables. In addition to open trench installation of the underground duct-bank system, the transmission line includes installation of cables on an existing bridge, two locations where the circuit is installed in casing pipe using jack-and-bore installation techniques, and one location where the circuit was installed using horizontal directional drilling techniques.

Due to the long length of this AC cable circuit, reactive support was installed at both ends of the transmission line within the substations.

### **Permitting**

The California Public Utilities Commission (CPUC) was the sole and exclusive authority for the project. Permits from local jurisdictions were also required. As part of the CPUC permit (CPCN), specific mitigation measures were required that affected the design and construction of the transmission

line. For example, special construction methods were required to protect special animal species, such as the installation of wildlife exclusion fencing adjacent to work areas. Overhead transmission line pole structures were painted to reduce the visual impact of the new line. Additional engineering evaluations were also required to ascertain the potential of increasing corrosion to adjacent utilities as a result of the new transmission line. All mitigation measures required as part of the CPCN were complied with and documented per CPUC requirements.



## SP23: Network upgrading around the city of Tunis (Tunisia)

### Overview

In order to develop the expansion of the economic activity of Tunis, S.T.E.G. (Société Tunisienne de l'Electricité et du gaz), the national Tunisian utility, has decided to launch one of the most important network upgrades realized during the last 10 years with underground cable connections.

### Details of circuits

The map shows the circuits installed around Tunis between 1998 and 2006.

The total cable lengths installed is nearly 500 km at 90 kV and nearly 200 km at 220 kV.

The following table gives details on every circuit. With the Rades II – Seltene circuits there is a special feature to be noted, which is that it is one of the longest 225 kV underground cable connection installed in the world with over 31 joint bays.



Map of the network around Tunis

### Information on Circuits

Number of circuits	km	Power (MVA)	Links	
			From	To
1 x 1200 mm <sup>2</sup> Al 90 kV 2 x 1600 mm <sup>2</sup> Al 90 kV	7	1 x 130 2 x 150	Tunis Sud	Naassen
1 x 1200 mm <sup>2</sup> Al 90 kV	11,6	1 x 130	Tunis Ouest	Zahrouni via Kasbah
1 x 1200 mm <sup>2</sup> Al 90 kV	12,4	1 x 130	El Kram	C.U. nord
1 x 1000 mm <sup>2</sup> Cu 90 kV 1 x 1200 mm <sup>2</sup> Al 90 kV	6,3	2 x 130	El Kram	Goulette
1 x 1000 mm <sup>2</sup> Cu 90 kV 1 x 1200 mm <sup>2</sup> Al 90 kV	7,2	2 x 130	El Kram	Gamarth
1 x 1200 mm <sup>2</sup> Al 90 kV	9	1 x 130	Tunis Sud	Mghira
1 x 1000 mm <sup>2</sup> Cu 90 kV	5,8	1 x 130	Tunis Nord	Tunis Ouest
1 x 1000 mm <sup>2</sup> Cu 90 kV	8	1 x 130	Naassen	Mghira
1 x 1000 mm <sup>2</sup> Cu 90 kV	9,1	1 x 130	Goulette	Tunis Centre
1 x 1600 mm <sup>2</sup> Al 90 kV	14	1 x 150	Tunis ouest	M'nihla
2 x 1200 mm <sup>2</sup> Cu 90 kV	13,3	2 x 150	Tunis Sud	Rades II
2 x 1200 mm <sup>2</sup> Cu 90 kV *	2,5	2 x 130	Goulette	Rades II
1 x 1600 mm <sup>2</sup> Al 90 kV	1	1 x 150	E/S El Kram/C.U.Nord	Lac Ouest
1 x 1600 mm <sup>2</sup> Al 90 kV *	15,5	1 x 150	Bizerte	Menzel Jmil
2 x 1000 mm <sup>2</sup> Cu 225 kV *	2,5	2 x 235	Goulette	Rades II
2 x 1000 mm <sup>2</sup> Cu 225 kV *	2,5	2 x 235	Goulette	Rades I
1 x 1000 mm <sup>2</sup> Cu 225 kV	1	1 x 235	Radès I	Rades II
2 x 1000 mm <sup>2</sup> Cu 225 kV	23,5	2 x 250	Rades II	Seltene
2 x 1000 mm <sup>2</sup> Cu 225 kV	2,5	2 x 250	E/S Rades II/ Seltene	SNCFT

\* : water canal crossing by using the directional drilling technique

### Technical key points

Two of the most critical points were:

- The connection between Rades I & II Power Stations and La Goulette old generating site by crossing 2 inlet channels near Tunis,
- Crossing the Bizerte inlet channel

These crossings were realised by using directional drilling with steel and HDPE tubes.

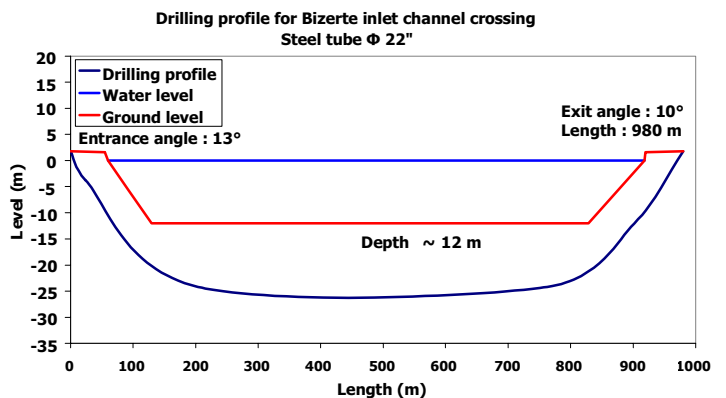
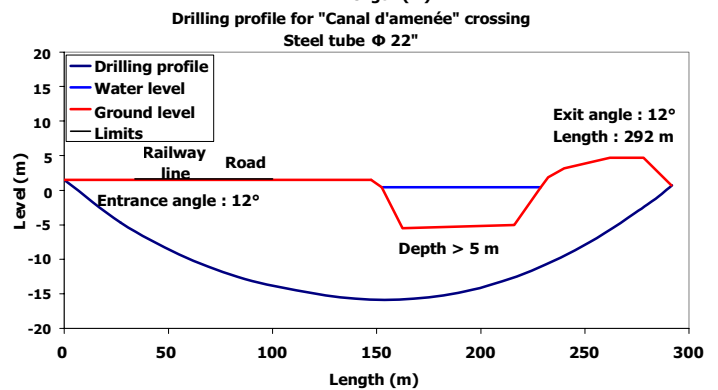
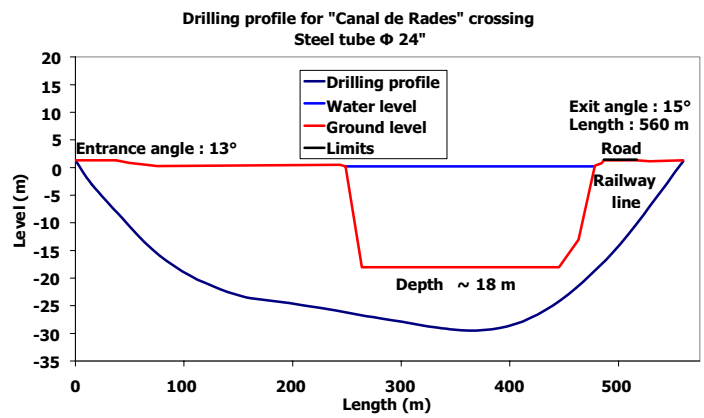
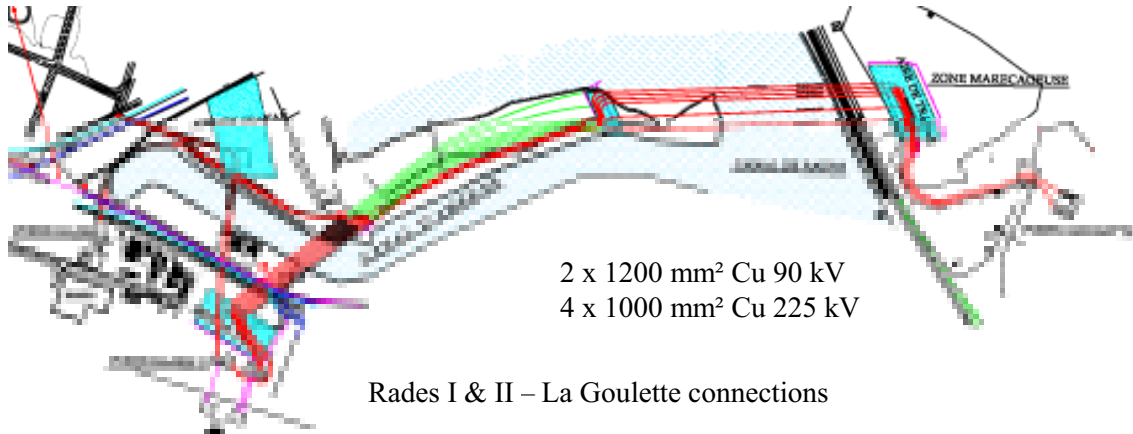

Directional drilling